

8 7 6 5 4 3 2 1

REVISIONS				
REV #	ECO #	DESCRIPTION	DATE	APPR
A			04/26/2018	D. King

D

D

C

C

B

B

A

A

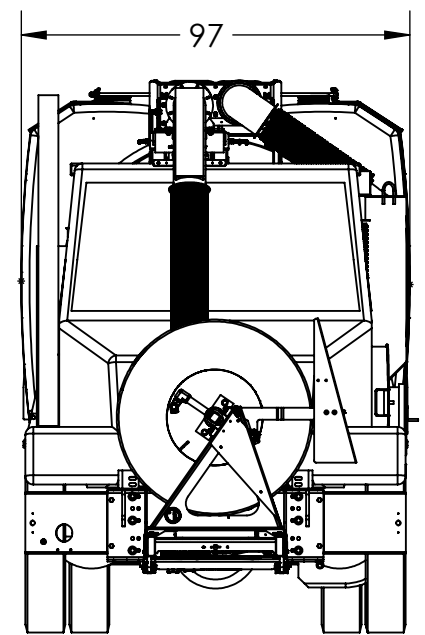
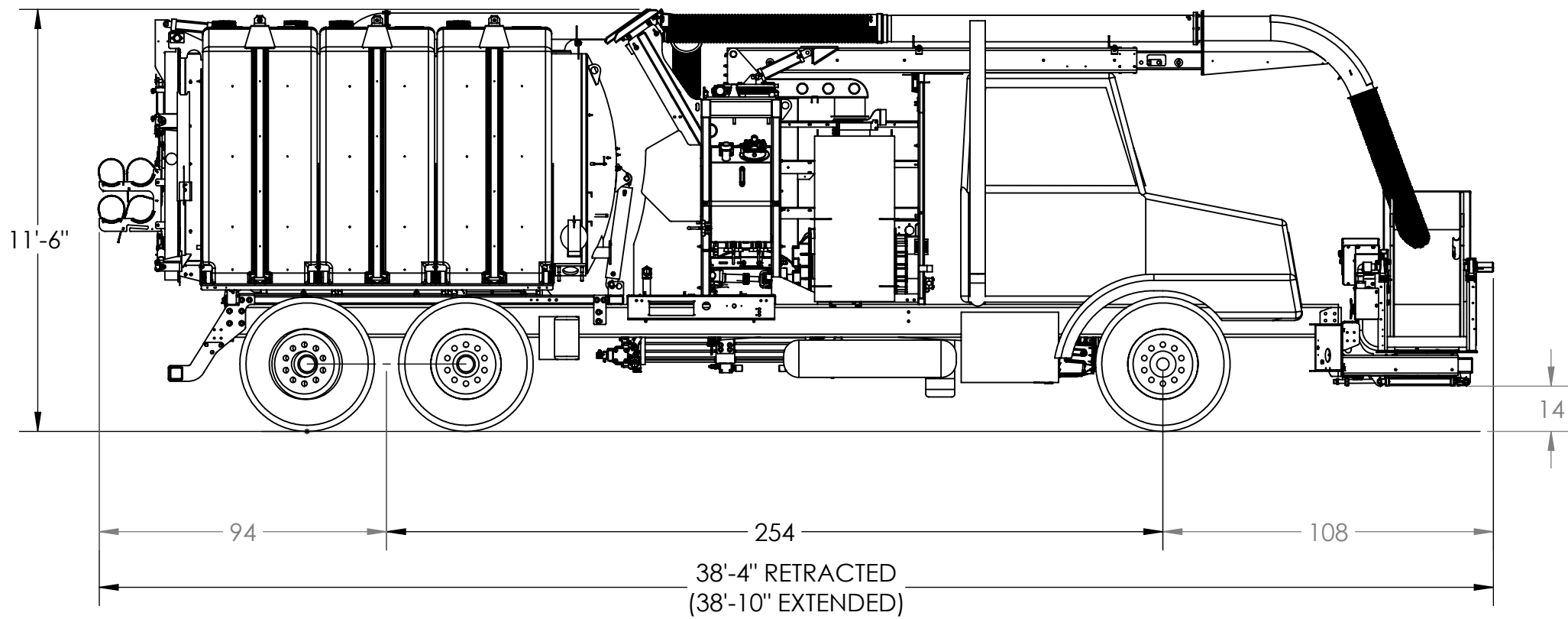

ALL DIMENSIONS AND SPECS ARE FOR REFERENCE ONLY. ACTUAL VALUES MAY VARY BASED ON CHASSIS MANUFACTURER AND SELECTED OPTIONS.

	NAME	DATE
DRAWN BY	A.Messing	03/01/2018
ENG APPR.	D. King	04/26/2018
MFG APPR.		

SUPER PRODUCTS
TRUCK MOUNTED VACUUM EQUIPMENT

TITLE:
LAYOUT, 12YD CAMEL
DIMENSIONS

DWG. NO.
0033428

REV
A

MATERIAL: []

PROPRIETARY AND CONFIDENTIAL
THE INFORMATION CONTAINED IN THIS DRAWING IS THE SOLE PROPERTY OF SUPER PRODUCTS. ANY REPRODUCTION IN PART OR AS A WHOLE WITHOUT THE WRITTEN PERMISSION OF SUPER PRODUCTS IS PROHIBITED.

UNLESS OTHERWISE SPECIFIED:
DIMENSIONS ARE IN INCHES
TOLERANCES ARE:
X.X ± 0.100
X.XX ± 0.060
X.XXX ± 0.030
ANGULAR: MACH ± 1° BEND ± 2°
INTERPRET GEOMETRIC TOLERANCING PER: ASME Y14.5

SIZE B SCALE: 1:48 WEIGHT: 0.00 SHEET 1 OF 3

8 7 6 5 4 3 2 1

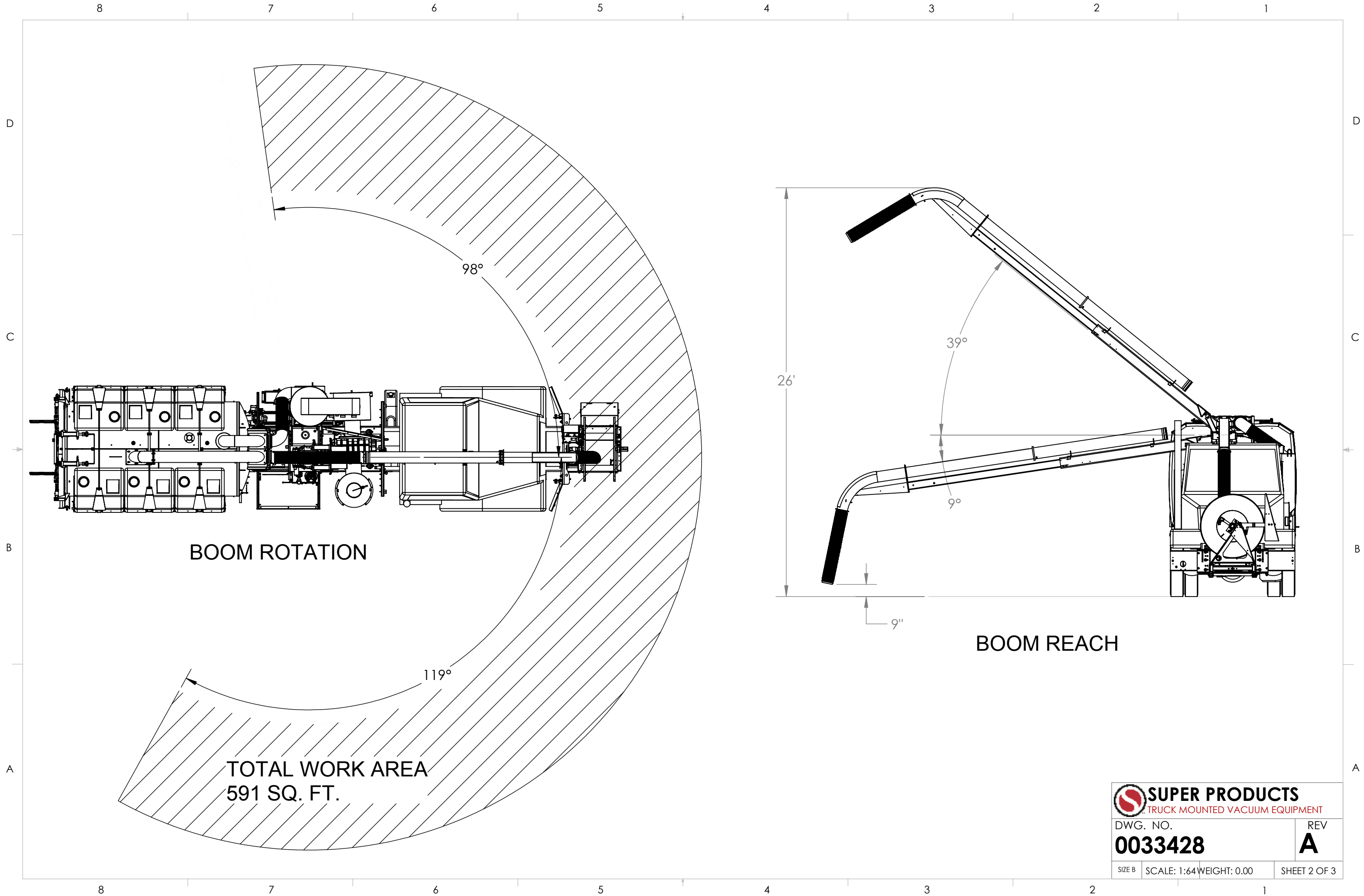

 SUPER PRODUCTS <small>TRUCK MOUNTED VACUUM EQUIPMENT</small>	
DWG. NO.	REV
0033428	A
SIZE B	SCALE: 1:64 WEIGHT: 0.00
SHEET 2 OF 3	

8 7 6 5 4 3 2 1

D
C
B
A

D
C
B
A

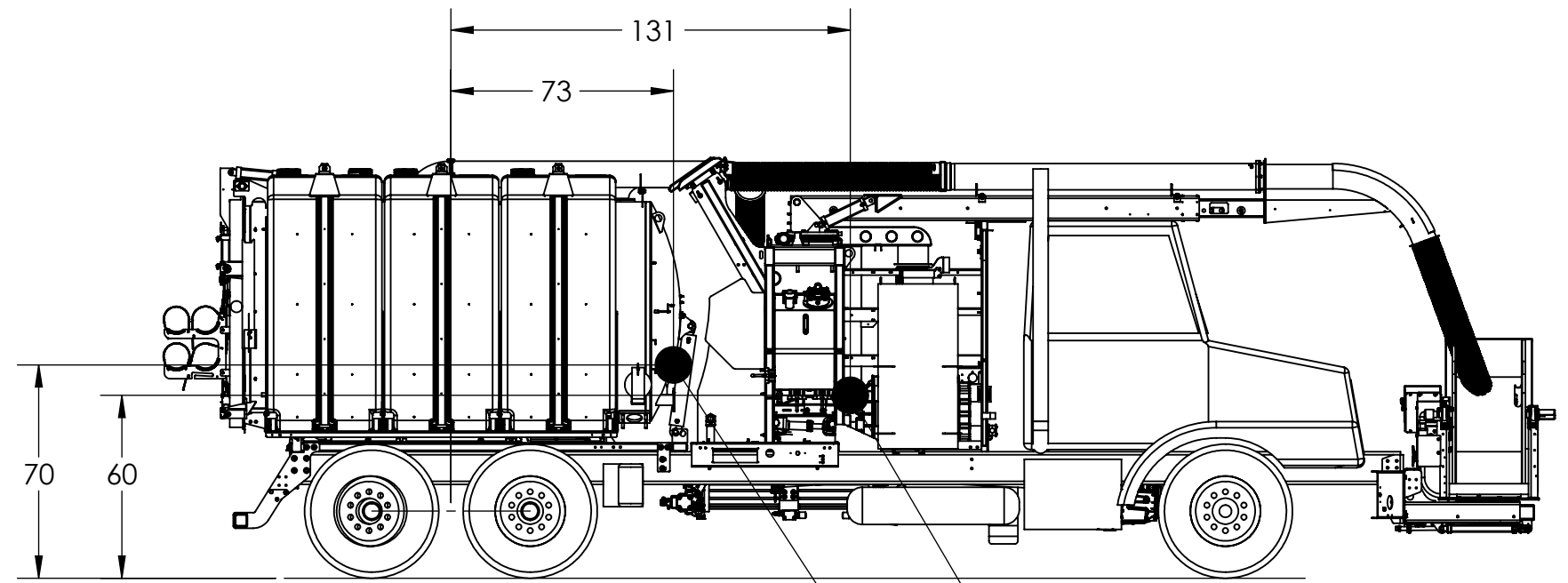

UNIT CENTER OF GRAVITY

CG - EMPTY

CG - FULL WATER TANKS,
DEBRIS BODY FULL OF WATER

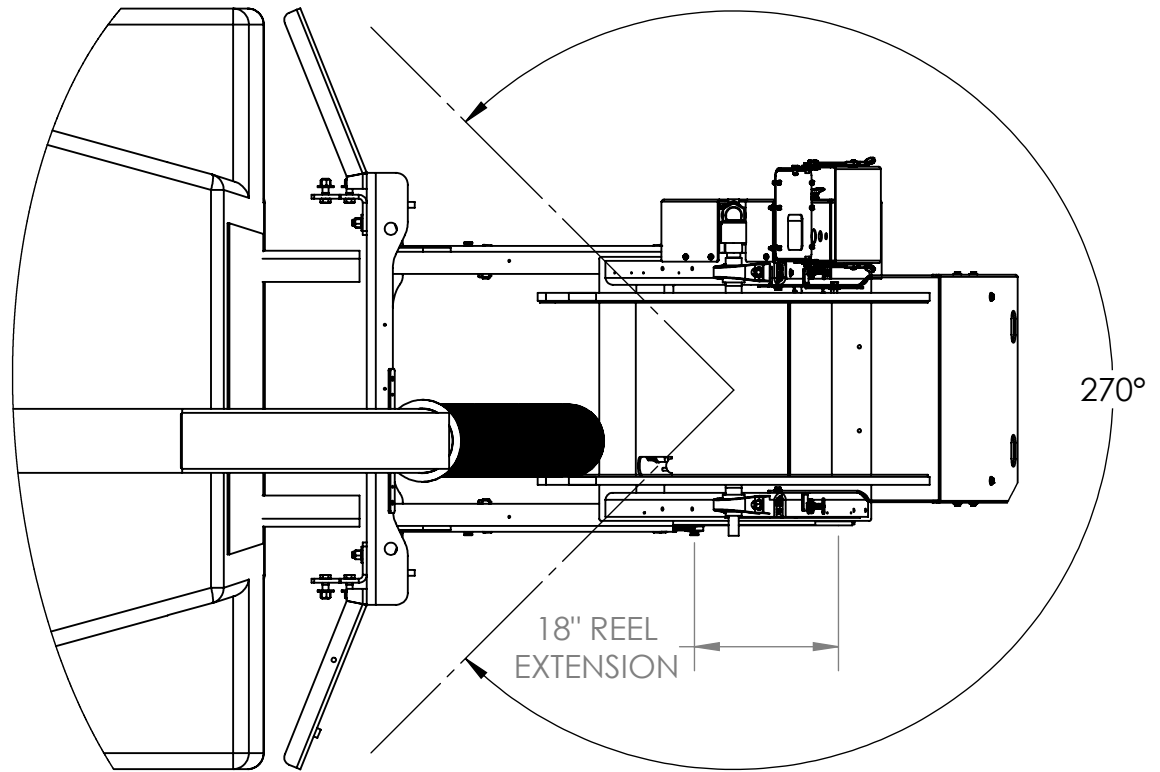

REEL ROTATION

FULL ROTATION CAN BE ACHIEVED
WHEN FULLY RETRACTED

DWG. NO.	REV
0033428	A
SIZE B	SCALE: 1:56 WEIGHT: 0.00 SHEET 3 OF 3

8 7 6 5 4 3 2 1