

Prepared for:
Larry Daub
Super Products Alamo Group
17000 W Cleveland
New Berlin, WI 53151
Phone: 2627847100

Prepared by:
Tony Bodway
TRUCK COUNTRY OF
WISCONSIN, INC.
2222 WEST RYAN ROAD
OAK CREEK, WI 53154
Phone: 414-761-3384

A proposal for
Super Products Alamo Group

Prepared by
TRUCK COUNTRY OF WISCONSIN, INC.
Tony Bodway

Nov 27, 2017

Freightliner 114SD

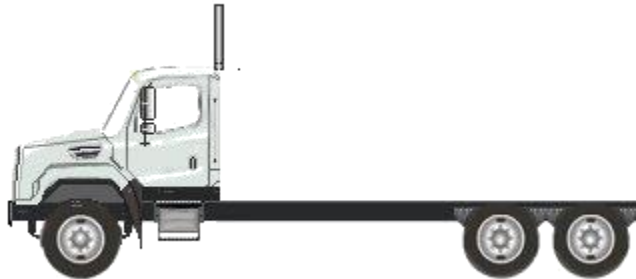

Components shown may not reflect all spec'd options and are not to scale

Prepared for:
 Larry Daub
 Super Products Alamo Group
 17000 W Cleveland
 New Berlin, WI 53151
 Phone: 2627847100

Prepared by:
 Tony Bodway
 TRUCK COUNTRY OF
 WISCONSIN, INC.
 2222 WEST RYAN ROAD
 OAK CREEK, WI 53154
 Phone: 414-761-3384

S P E C I F I C A T I O N P R O P O S A L

Data Code	Description	Weight Front	Weight Rear
Price Level			
PRL-13D	SD PRL-13D (EFF:02/27/15)		
Data Version			
DRL-002	SPECPRO21 DATA RELEASE VER 002		
Interior Convenience/Driver Retention Package			
055-998	NO INTERIOR CONVENIENCE PACKAGE		
Vehicle Configuration			
001-177	114SD CONVENTIONAL CHASSIS	7,934	6,576
004-219	2019 MODEL YEAR SPECIFIED		
002-004	SET BACK AXLE - TRUCK	480	-480
019-002	STRAIGHT TRUCK PROVISION		
003-001	LH PRIMARY STEERING LOCATION		
General Service			
AA1-002	TRUCK CONFIGURATION		
AA6-001	DOMICILED, USA 50 STATES (INCLUDING CALIFORNIA AND CARB OPT-IN STATES)		
A85-010	UTILITY/REPAIR/MAINTENANCE SERVICE		
A84-1UT	UTILITY BUSINESS SEGMENT		
AA4-002	LIQUID BULK COMMODITY		
AA5-002	TERRAIN/DUTY: 100% (ALL) OF THE TIME, IN TRANSIT, IS SPENT ON PAVED ROADS		
AB1-008	MAXIMUM 8% EXPECTED GRADE		
AB5-001	SMOOTH CONCRETE OR ASPHALT PAVEMENT - MOST SEVERE IN-TRANSIT (BETWEEN SITES) ROAD SURFACE		
995-1A0	FREIGHTLINER SD VOCATIONAL WARRANTY		
A66-99D	EXPECTED FRONT AXLE(S) LOAD : 20000.0 lbs		
A68-99D	EXPECTED REAR DRIVE AXLE(S) LOAD : 40000.0 lbs		
A63-99D	EXPECTED GROSS VEHICLE WEIGHT CAPACITY : 60000.0 lbs		

Prepared for:
 Larry Daub
 Super Products Alamo Group
 17000 W Cleveland
 New Berlin, WI 53151
 Phone: 2627847100

Prepared by:
 Tony Bodway
 TRUCK COUNTRY OF
 WISCONSIN, INC.
 2222 WEST RYAN ROAD
 OAK CREEK, WI 53154
 Phone: 414-761-3384

Data Code	Description	Weight Front	Weight Rear
Truck Service			
AA3-034	SEWER/INDUSTRIAL VACUUM BODY		
AF3-2AY	SUPER PRODUCTS		
Engine			
101-22V	CUM L9 370 HP @ 2000 RPM, 2100 GOV RPM, 1250 LB/FT @ 1400 RPM	-850	-70
Electronic Parameters			
79A-074	74 MPH ROAD SPEED LIMIT		
79B-000	CRUISE CONTROL SPEED LIMIT SAME AS ROAD SPEED LIMIT		
79K-005	PTO MODE ENGINE RPM LIMIT - 900 RPM		
79P-002	PTO RPM WITH CRUISE SET SWITCH - 700 RPM		
79Q-002	PTO RPM WITH CRUISE RESUME SWITCH - 700 RPM		
79S-001	PTO MODE CANCEL VEHICLE SPEED - 5 MPH		
79U-007	PTO GOVERNOR RAMP RATE - 250 RPM PER SECOND		
79V-001	ENABLE REGENERATION IN PTO MODE		
79W-002	TWO REMOTE PTO SPEEDS		
79X-001	REMOTE PTO SPEED 1 SETTING - 700 RPM		
79Y-001	REMOTE PTO SPEED 2 SETTING - 900 RPM		
80G-002	PTO MINIMUM RPM - 700		
80J-001	REGEN INHIBIT SPEED THRESHOLD - 0 MPH		
Engine Equipment			
99C-017	2016 ONBOARD DIAGNOSTICS/2010 EPA/CARB/FINAL GHG17 CONFIGURATION		
99D-011	2008 CARB EMISSION CERTIFICATION - CLEAN IDLE (INCLUDES 6X4 INCH LABEL ON LOWER FORWARD CORNER OF DRIVER DOOR)		
PMT-998	NO 2013 ENGINE ESCALATOR		
13E-001	STANDARD OIL PAN		
105-001	ENGINE MOUNTED OIL CHECK AND FILL		
014-1B5	SIDE OF HOOD AIR INTAKE WITH DONALDSON HIGH CAPACITY AIR CLEANER WITH SAFETY ELEMENT, FIREWALL MOUNTED		
124-1D7	DR 12V 160 AMP 28-SI QUADRAMOUNT PAD ALTERNATOR WITH REMOTE BATTERY VOLT SENSE		
292-098	(2) ALLIANCE MODEL 1231, GROUP 31, 12 VOLT MAINTENANCE FREE 2250 CCA THREADED STUD BATTERIES	-50	-10

Prepared for:
 Larry Daub
 Super Products Alamo Group
 17000 W Cleveland
 New Berlin, WI 53151
 Phone: 2627847100

Prepared by:
 Tony Bodway
 TRUCK COUNTRY OF
 WISCONSIN, INC.
 2222 WEST RYAN ROAD
 OAK CREEK, WI 53154
 Phone: 414-761-3384

Data Code	Description	Weight Front	Weight Rear
290-017	BATTERY BOX FRAME MOUNTED		
281-004	BATTERY JUMPERS WITH MEGA FUSE JUNCTION BLOCK (MFJB)	4	
282-001	SINGLE BATTERY BOX FRAME MOUNTED LH SIDE UNDER CAB		
291-017	WIRE GROUND RETURN FOR BATTERY CABLES WITH ADDITIONAL FRAME GROUND RETURN		
289-001	NON-POLISHED BATTERY BOX COVER		
293-058	POSITIVE LOAD DISCONNECT WITH CAB MOUNTED CONTROL SWITCH MOUNTED OUTBOARD DRIVER SEAT	8	
107-032	CUMMINS TURBOCHARGED 18.7 CFM AIR COMPRESSOR WITH INTERNAL SAFETY VALVE		
152-041	ELECTRONIC ENGINE INTEGRAL SHUTDOWN PROTECTION SYSTEM		
128-076	CUMMINS EXHAUST BRAKE INTEGRAL WITH VARIABLE GEOMETRY TURBO WITH ON/OFF DASH SWITCH	20	
016-1C2	RH OUTBOARD UNDER STEP MOUNTED HORIZONTAL AFTERTREATMENT SYSTEM ASSEMBLY WITH RH B-PILLAR MOUNTED VERTICAL TAILPIPE	30	25
28F-007	ENGINE AFTERTREATMENT DEVICE, AUTOMATIC OVER THE ROAD ACTIVE REGENERATION AND DASH MOUNTED SINGLE REGENERATION REQUEST/INHIBIT SWITCH		
239-026	10 FOOT 06 INCH (126 INCH+0/-5.9 INCH) EXHAUST SYSTEM HEIGHT		
237-1CR	RH CURVED VERTICAL TAILPIPE B-PILLAR MOUNTED ROUTED FROM STEP		
23U-001	6 GALLON DIESEL EXHAUST FLUID TANK	-35	-10
30N-003	100 PERCENT DIESEL EXHAUST FLUID FILL		
23Y-002	DIESEL EXHAUST FLUID PUMP MOUNTED AFT OF DIESEL EXHAUST FLUID TANK		
43X-002	LH MEDIUM DUTY STANDARD DIESEL EXHAUST FLUID TANK LOCATION		
43Y-001	STANDARD DIESEL EXHAUST FLUID TANK CAP		
242-011	ALUMINUM AFTERTREATMENT DEVICE/MUFFLER/TAILOPIPE SHIELD(S)		
273-048	HORTON 2-SPEED DRIVEMASTER ADVANTAGE POLAREXTREME FAN DRIVE		
276-002	AUTOMATIC FAN CONTROL WITH DASH SWITCH AND INDICATOR LIGHT, NON ENGINE MOUNTED		
110-003	CUMMINS SPIN ON FUEL FILTER		

Prepared for:
 Larry Daub
 Super Products Alamo Group
 17000 W Cleveland
 New Berlin, WI 53151
 Phone: 2627847100

Prepared by:
 Tony Bodway
 TRUCK COUNTRY OF
 WISCONSIN, INC.
 2222 WEST RYAN ROAD
 OAK CREEK, WI 53154
 Phone: 414-761-3384

Data Code	Description	Weight Front	Weight Rear
118-008	COMBINATION FULL FLOW/BYPASS OIL FILTER		
266-017	1300 SQUARE INCH ALUMINUM RADIATOR	-20	
103-039	ANTIFREEZE TO -34F, OAT (NITRITE AND SILICATE FREE) EXTENDED LIFE COOLANT		
171-007	GATES BLUE STRIPE COOLANT HOSES OR EQUIVALENT		
172-001	CONSTANT TENSION HOSE CLAMPS FOR COOLANT HOSES		
270-016	RADIATOR DRAIN VALVE		
138-011	PHILLIPS-TEMRO 1000 WATT/115 VOLT BLOCK HEATER	4	
140-053	BLACK PLASTIC ENGINE HEATER RECEPTACLE MOUNTED UNDER LH DOOR		
132-004	ELECTRIC GRID AIR INTAKE WARMER		
155-058	DELCO 12V 38MT HD STARTER WITH INTEGRATED MAGNETIC SWITCH	-10	

Transmission

342-582	ALLISON 3000 RDS AUTOMATIC TRANSMISSION WITH PTO PROVISION
---------	--

Transmission Equipment

343-338	ALLISON VOCATIONAL PACKAGE 222 - AVAILABLE ON 3000/4000 PRODUCT FAMILIES WITH VOCATIONAL MODEL RDS
84B-012	ALLISON VOCATIONAL RATING FOR ON/OFF HIGHWAY APPLICATIONS AVAILABLE WITH ALL PRODUCT FAMILIES
84C-023	PRIMARY MODE GEARS, LOWEST GEAR 1, START GEAR 1, HIGHEST GEAR 6, AVAILABLE FOR 3000/4000 PRODUCT FAMILIES ONLY
84D-023	SECONDARY MODE GEARS, LOWEST GEAR 1, START GEAR 1, HIGHEST GEAR 6, AVAILABLE FOR 3000/4000 PRODUCT FAMILIES ONLY
84E-017	S5 PERFORMANCE LIMITING PRIMARY SHIFT SCHEDULE, AVAILABLE FOR 3000/4000 PRODUCT FAMILIES ONLY
84F-016	S5 PERFORMANCE LIMITING SECONDARY SHIFT SCHEDULE, AVAILABLE FOR 3000/4000 PRODUCT FAMILIES ONLY
84G-013	2100 RPM PRIMARY MODE SHIFT SPEED
84H-013	2100 RPM SECONDARY MODE SHIFT SPEED
84L-010	DISABLE - LOAD BASED SHIFT SCHEDULE, DISABLE - VEHICLE ACCELERATION CONTROL
84U-000	DRIVER SWITCH INPUT - DEFAULT - NO SWITCHES

Prepared for:
 Larry Daub
 Super Products Alamo Group
 17000 W Cleveland
 New Berlin, WI 53151
 Phone: 2627847100

Prepared by:
 Tony Bodway
 TRUCK COUNTRY OF
 WISCONSIN, INC.
 2222 WEST RYAN ROAD
 OAK CREEK, WI 53154
 Phone: 414-761-3384

Data Code	Description	Weight Front	Weight Rear
353-038	MARKER LAMP CONNECTION FOR BODY BUILDERS		
34C-001	ELECTRONIC TRANSMISSION CUSTOMER ACCESS CONNECTOR FIREWALL MOUNTED		
362-158	CUSTOMER INSTALLED MUNCIE CS10 SERIES PTO		
363-001	PTO MOUNTING, LH SIDE OF MAIN TRANSMISSION		
341-018	MAGNETIC PLUGS, ENGINE DRAIN, TRANSMISSION DRAIN, AXLE(S) FILL AND DRAIN		
345-003	PUSH BUTTON ELECTRONIC SHIFT CONTROL, DASH MOUNTED		
97G-004	TRANSMISSION PROGNOSTICS - ENABLED 2013		
370-015	WATER TO OIL TRANSMISSION COOLER, IN RADIATOR END TANK	-15	
346-003	TRANSMISSION OIL CHECK AND FILL WITH ELECTRONIC OIL LEVEL CHECK		
35T-001	SYNTHETIC TRANSMISSION FLUID (TES-295 COMPLIANT)		

Front Axle and Equipment

400-1BB	DETROIT DA-F-20.0-5 20,000# FL1 71.0 KPI/3.74 DROP SINGLE FRONT AXLE	210	
402-030	MERITOR 16.5X6 Q+ CAST SPIDER CAM FRONT BRAKES, DOUBLE ANCHOR, FABRICATED SHOES	10	
403-002	NON-ASBESTOS FRONT BRAKE LINING		
419-023	CONMET CAST IRON FRONT BRAKE DRUMS		
409-006	FRONT OIL SEALS		
408-001	VENTED FRONT HUB CAPS WITH WINDOW, CENTER AND SIDE PLUGS - OIL		
416-022	STANDARD SPINDLE NUTS FOR ALL AXLES		
405-003	HALDEX AUTOMATIC FRONT SLACK ADJUSTERS		
406-001	STANDARD KING PIN BUSHINGS		
536-055	TRW THP-60 POWER STEERING WITH RCH45 AUXILIARY GEAR	130	
539-003	POWER STEERING PUMP		
534-003	4 QUART POWER STEERING RESERVOIR		
533-001	OIL/AIR POWER STEERING COOLER		
40T-001	ORGANIC SAE 80/90 FRONT AXLE LUBE		

Front Suspension

Prepared for:
 Larry Daub
 Super Products Alamo Group
 17000 W Cleveland
 New Berlin, WI 53151
 Phone: 2627847100

Prepared by:
 Tony Bodway
 TRUCK COUNTRY OF
 WISCONSIN, INC.
 2222 WEST RYAN ROAD
 OAK CREEK, WI 53154
 Phone: 414-761-3384

Data Code	Description	Weight Front	Weight Rear
620-006	20,000# FLAT LEAF FRONT SUSPENSION	310	
619-004	GRAPHITE BRONZE BUSHINGS WITH SEALS - FRONT SUSPENSION		
410-001	FRONT SHOCK ABSORBERS		
Rear Axle and Equipment			
420-1K3	MT-40-14X 40,000# R-SERIES TANDEM REAR AXLE		-40
421-529	5.29 REAR AXLE RATIO		
424-003	IRON REAR AXLE CARRIER WITH OPTIONAL HEAVY DUTY AXLE HOUSING		40
* 385-005	DRIVELINE SPACER FOR CUSTOMER FURNISHED EQUIPMENT REF CAMEL 1200 DRAWING	40	40
386-073	MXL 17T MERITOR EXTENDED LUBE MAIN DRIVELINE WITH HALF ROUND YOKES	40	40
388-073	MXL 17T MERITOR EXTENDED LUBE INTERAXLE DRIVELINE WITH HALF ROUND YOKES		
878-019	(1) INTERAXLE LOCK VALVE FOR TANDEM OR TRIDEM DRIVE AXLES		
87A-001	BLINKING LAMP WITH EACH INTERAXLE LOCK SWITCH, INTERAXLE UNLOCK DEFAULT WITH IGNITION OFF		
423-020	MERITOR 16.5X7 Q+ CAST SPIDER CAM REAR BRAKES, DOUBLE ANCHOR, FABRICATED SHOES		
433-002	NON-ASBESTOS REAR BRAKE LINING		
434-003	STANDARD BRAKE CHAMBER LOCATION		
451-023	CONMET CAST IRON REAR BRAKE DRUMS		
440-006	REAR OIL SEALS		
426-1B3	BENDIX EVERSURE LONGSTROKE 2-DRIVE AXLES SPRING PARKING CHAMBERS		
428-003	HALDEX AUTOMATIC REAR SLACK ADJUSTERS		
41T-001	ORGANIC SAE 80/90 REAR AXLE LUBE		
42T-001	STANDARD REAR AXLE BREATHER(S)		
Rear Suspension			
622-1CH	HENDRICKSON RT403 @40,000# REAR SUSPENSION		670
621-015	HENDRICKSON RT/RTE - 6.00" SADDLE		
431-001	STANDARD AXLE SEATS IN AXLE CLAMP GROUP		
624-009	54 INCH AXLE SPACING		10

Prepared for:
 Larry Daub
 Super Products Alamo Group
 17000 W Cleveland
 New Berlin, WI 53151
 Phone: 2627847100

Prepared by:
 Tony Bodway
 TRUCK COUNTRY OF
 WISCONSIN, INC.
 2222 WEST RYAN ROAD
 OAK CREEK, WI 53154
 Phone: 414-761-3384

Data Code	Description	Weight Front	Weight Rear	
628-004	STEEL BEAMS AND RUBBER CENTER BUSHINGS WITH BAR PIN ADJUSTABLE END CONNECTIONS			
623-005	FORE/AFT CONTROL RODS			
Brake System				
490-100	WABCO 4S/4M ABS WITHOUT TRACTION CONTROL			
871-001	REINFORCED NYLON, FABRIC BRAID AND WIRE BRAID CHASSIS AIR LINES			
904-001	FIBER BRAID PARKING BRAKE HOSE			
412-001	STANDARD BRAKE SYSTEM VALVES			
46D-002	STANDARD AIR SYSTEM PRESSURE PROTECTION SYSTEM			
413-002	STD U.S. FRONT BRAKE VALVE			
432-003	RELAY VALVE WITH 5-8 PSI CRACK PRESSURE, NO REAR PROPORTIONING VALVE			
480-009	BW AD-9 BRAKE LINE AIR DRYER WITH HEATER	20		
* 479-007	AIR DRYER MOUNTED OUTBOARD ON RH RAIL BACK OF CAB REF JP4407			
* 460-001	STEEL AIR BRAKE RESERVOIRS TRIPLE TANK RH RAIL AT 3150 REF JP4407			
477-001	PULL CABLE ON WET TANK, PETCOCK DRAIN VALVES ON ALL OTHER AIR TANKS			
Trailer Connections				
335-004	UPGRADED CHASSIS MULTIPLEXING UNIT			
Wheelbase & Frame				
	545-645	6450MM (254 INCH) WHEELBASE		
N	546-101	11/32X3-1/2X10-15/16 INCH STEEL FRAME (8.73MMX277.8MM/0.344X10.94 INCH) 120KSI	580	-70
	547-001	1/4 INCH (6.35MM) C-CHANNEL INNER FRAME REINFORCEMENT	250	430
	552-023	1325MM (52 INCH) REAR FRAME OVERHANG		
	55W-005	FRAME OVERHANG RANGE: 51 INCH TO 60 INCH	20	-70
*	549-095	12 INCH INTEGRAL FRONT FRAME EXTENSION WITH NO BUMPER NOTCH AND 0.25" INSERT		
	AC8-99D	CALC'D BACK OF CAB TO REAR SUSP C/L (CA) : 188.45 in		
	AE8-99D	CALCULATED EFFECTIVE BACK OF CAB TO REAR SUSPENSION C/L (CA) : 185.45 in		

Prepared for:
 Larry Daub
 Super Products Alamo Group
 17000 W Cleveland
 New Berlin, WI 53151
 Phone: 2627847100

Prepared by:
 Tony Bodway
 TRUCK COUNTRY OF
 WISCONSIN, INC.
 2222 WEST RYAN ROAD
 OAK CREEK, WI 53154
 Phone: 414-761-3384

Data Code	Description	Weight Front	Weight Rear
AE4-99D	CALC'D FRAME LENGTH - OVERALL : 336.12		
AM6-99D	CALC'D SPACE AVAILABLE FOR DECKPLATE : 188.45 in		
FSS-0LH	CALCULATED FRAME SPACE LH SIDE : 122.87 in		
FSS-0RH	CALCULATED FRAME SPACE RH SIDE : 141.47 in		
553-001	SQUARE END OF FRAME		
550-001	FRONT CLOSING CROSSMEMBER		
559-001	STANDARD WEIGHT ENGINE CROSSMEMBER		
* 562-341	STANDARD MIDSHIP #1 CROSSMEMBER MOUNTED 1035MM (41 INCH) FROM BACK OF CAB		
* 563-326	MIDSHIP #2 CROSSMEMBER MOUNTED 650MM (26") FROM MIDSHIP #1		
	OMIT 564		
* 572-072	STANDARD REARMOST XMBR MOUTED 975MM AFT OF REAR SUSPENSION CENTERLINE		
565-001	STANDARD SUSPENSION CROSSMEMBER		

Chassis Equipment

556-997	OMIT FRONT BUMPER, CUSTOMER INSTALLED SPECIAL BUMPER, DOES NOT COMPLY WITH FMCSR 393.203	-100	
551-001	HUCK-SPIN ROUND COLLAR CHASSIS FASTENERS SUSPENSIONS ONLY		
489-998	NO TIRE PRESSURE CONTROL/SENSOR		
* 606-125	DRLG PREP FOR SUPER PRODUCTS PER DWG 0024917, REV J		
	PLEASE NOTE THIS IS A NEW REV		
605-103	D15-28195-000 CENTER PUNCH TO MARK CENTERLINE OF REAR SUSPENSION ON TOP FLANGE OF FRAME		

Fuel Tanks

204-152	70 GALLON/264 LITER ALUMINUM FUEL TANK - LH	5	
218-006	25 INCH DIAMETER FUEL TANK(S)		
215-005	PLAIN ALUMINUM/PAINTED STEEL FUEL/HYDRAULIC TANK(S) WITH PAINTED BANDS		
212-007	FUEL TANK(S) FORWARD		
664-001	PLAIN STEP FINISH		
205-001	FUEL TANK CAP(S)		

Prepared for:
 Larry Daub
 Super Products Alamo Group
 17000 W Cleveland
 New Berlin, WI 53151
 Phone: 2627847100

Prepared by:
 Tony Bodway
 TRUCK COUNTRY OF
 WISCONSIN, INC.
 2222 WEST RYAN ROAD
 OAK CREEK, WI 53154
 Phone: 414-761-3384

Data Code	Description	Weight Front	Weight Rear
122-1J1	DETROIT FUEL/WATER SEPARATOR WITH WATER IN FUEL SENSOR, HAND PRIMER AND 12 VOLT PREHEATER	10	
216-020	EQUIFLO INBOARD FUEL SYSTEM		
202-016	HIGH TEMPERATURE REINFORCED NYLON FUEL LINE		
Tires			
093-0TB	MICHELIN XZY-3 425/65R22.5 20 PLY RADIAL FRONT TIRES	196	
094-1UX	MICHELIN X MULTI D 11R22.5 14 PLY RADIAL REAR TIRES		192
Hubs			
418-060	CONMET PRESET PLUS PREMIUM IRON FRONT HUBS		
450-060	CONMET PRESET PLUS PREMIUM IRON REAR HUBS		
Wheels			
502-566	MAXION WHEELS 10035 22.5X12.25 10-HUB PILOT 4.75 INSET 5-HAND STEEL DISC FRONT WHEELS	102	
505-524	MAXION WHEELS 90541 22.5X8.25 10-HUB PILOT 2-HAND STEEL DISC REAR WHEELS		
50W-998	NO RIM/WHEEL TIRE PRESSURE SENSOR		
498-009	WHEEL STUDS FOR CUSTOMER INSTALLED HUB PILOTED DUALED ALUMINUM WHEELS, ALL		
Cab Exterior			
829-1A2	114 INCH BBC FLAT ROOF ALUMINUM CONVENTIONAL CAB		
650-008	AIR CAB MOUNTING		
648-002	NONREMOVABLE BUGSCREEN MOUNTED BEHIND GRILLE		
667-004	FRONT FENDERS SET-BACK AXLE		
754-017	BOLT-ON MOLDED FLEXIBLE FENDER EXTENSIONS	10	
678-018	LH AND RH EXTERIOR GRAB HANDLES WITH SINGLE RUBBER INSERT		
645-002	BRIGHT FINISH RADIATOR SHELL/HOOD BEZEL		
646-042	STATIONARY BLACK GRILLE WITH BRIGHT ACCENTS		
65X-003	CHROME HOOD MOUNTED AIR INTAKE GRILLE		
644-004	FIBERGLASS HOOD		

Prepared for:
 Larry Daub
 Super Products Alamo Group
 17000 W Cleveland
 New Berlin, WI 53151
 Phone: 2627847100

Prepared by:
 Tony Bodway
 TRUCK COUNTRY OF
 WISCONSIN, INC.
 2222 WEST RYAN ROAD
 OAK CREEK, WI 53154
 Phone: 414-761-3384

Data Code	Description	Weight Front	Weight Rear
690-007	HOOD LINER INSULATION WITH SINGLE FIREWALL INSULATION		
727-1AF	SINGLE 14 INCH ROUND HADLEY AIR HORN UNDER LH DECK		
726-001	SINGLE ELECTRIC HORN		
728-001	SINGLE HORN SHIELD		
657-1CV	DOOR LOCKS AND IGNITION SWITCH KEYED THE SAME WITH (4) KEYS		
575-001	REAR LICENSE PLATE MOUNT END OF FRAME		
312-067	HALOGEN COMPOSITE HEADLAMPS WITH BRIGHT BEZELS		
302-047	LED AERODYNAMIC MARKER LIGHTS		
311-012	DAYTIME RUNNING LIGHTS - LOW BEAM ONLY		
294-046	OMIT STOP/TAIL/BACKUP LIGHTS AND PROVIDE WIRING WITH SEPARATE STOP/TURN WIRES TO 4 FEET BEYOND END OF FRAME		-5
300-015	STANDARD FRONT TURN SIGNAL LAMPS		
744-1BG	DUAL WEST COAST MOLDED-IN COLOR HEATED MIRRORS		
797-001	DOOR MOUNTED MIRRORS		
796-001	102 INCH EQUIPMENT WIDTH		
743-1AP	LH AND RH 8 INCH MOLDED-IN COLOR CONVEX MIRRORS MOUNTED UNDER PRIMARY MIRRORS		
729-001	STANDARD SIDE/REAR REFLECTORS		
677-055	RH AFTERTREATMENT SYSTEM CAB ACCESS WITH POLISHED DIAMOND PLATE COVER		
768-043	63X14 INCH TINTED REAR WINDOW		
661-003	TINTED DOOR GLASS LH AND RH WITH TINTED NON-OPERATING WING WINDOWS		
654-027	RH AND LH ELECTRIC POWERED WINDOWS, PASSENGER SWITCHES ON DOOR(S)	4	
663-013	TINTED WINDSHIELD		
659-019	2 GALLON WINDSHIELD WASHER RESERVOIR WITHOUT FLUID LEVEL INDICATOR, FRAME MOUNTED		

Cab Interior

707-1AK	OPAL GRAY VINYL INTERIOR		
706-026	MOLDED PLASTIC DOOR PANEL WITHOUT VINYL INSERT WITH ALUMINUM KICKPLATE LOWER DOOR		

Prepared for:
 Larry Daub
 Super Products Alamo Group
 17000 W Cleveland
 New Berlin, WI 53151
 Phone: 2627847100

Prepared by:
 Tony Bodway
 TRUCK COUNTRY OF
 WISCONSIN, INC.
 2222 WEST RYAN ROAD
 OAK CREEK, WI 53154
 Phone: 414-761-3384

Data Code	Description	Weight Front	Weight Rear
708-026	MOLDED PLASTIC DOOR PANEL WITHOUT VINYL INSERT WITH ALUMINUM KICKPLATE LOWER DOOR		
772-006	BLACK MATS WITH SINGLE INSULATION		
785-004	DASH MOUNTED ASH TRAY(S) WITHOUT LIGHTER		
691-008	FORWARD ROOF MOUNTED CONSOLE WITH UPPER STORAGE COMPARTMENTS WITHOUT NETTING		
694-010	IN DASH STORAGE BIN		
696-012	CENTER STORAGE CONSOLE MOUNTED ON BACKWALL	20	
742-007	(2) CUP HOLDERS LH AND RH DASH		
680-006	GRAY/CHARCOAL FLAT DASH		
860-004	SMART SWITCH EXPANSION MODULE		
720-003	5 LB. FIRE EXTINGUISHER	10	
700-002	HEATER, DEFROSTER AND AIR CONDITIONER		
701-001	STANDARD HVAC DUCTING		
703-005	MAIN HVAC CONTROLS WITH RECIRCULATION SWITCH		
170-015	STANDARD HEATER PLUMBING		
130-033	DENSO HEAVY DUTY AIR CONDITIONER COMPRESSOR		
702-002	BINARY CONTROL, R-134A		
739-033	STANDARD INSULATION		
285-013	SOLID-STATE CIRCUIT PROTECTION AND FUSES		
280-007	12V NEGATIVE GROUND ELECTRICAL SYSTEM		
324-014	DOME LIGHT WITH 3-WAY SWITCH ACTIVATED BY LH AND RH DOORS		
655-005	LH AND RH ELECTRIC DOOR LOCKS		
284-045	(2) 12 VOLT POWER RECEPTACLES MOUNTED IN DASH		
722-028	TRIANGULAR REFLECTORS KIT WITHOUT FLARES SHIPPED LOOSE IN CAB	10	
756-1J3	BASIC HIGH BACK AIR SUSPENSION DRIVER SEAT WITH MECHANICAL LUMBAR AND INTEGRATED CUSHION EXTENSION	30	
760-1J3	BASIC HIGH BACK AIR SUSPENSION PASSENGER SEAT WITH MECHANICAL LUMBAR AND INTEGRATED CUSHION EXTENSION	25	10
759-005	DUAL DRIVER AND PASSENGER SEAT ARMRESTS	8	

Prepared for:
 Larry Daub
 Super Products Alamo Group
 17000 W Cleveland
 New Berlin, WI 53151
 Phone: 2627847100

Prepared by:
 Tony Bodway
 TRUCK COUNTRY OF
 WISCONSIN, INC.
 2222 WEST RYAN ROAD
 OAK CREEK, WI 53154
 Phone: 414-761-3384

Data Code	Description	Weight Front	Weight Rear
711-004	LH AND RH INTEGRAL DOOR PANEL ARMRESTS		
758-014	BLACK CORDURA PLUS CLOTH DRIVER SEAT COVER		
761-014	BLACK CORDURA PLUS CLOTH PASSENGER SEAT COVER		
763-101	BLACK SEAT BELTS		
532-001	FIXED STEERING COLUMN		
540-015	4-SPOKE 18 INCH (450MM) STEERING WHEEL		
765-002	DRIVER AND PASSENGER INTERIOR SUN VISORS		

Instruments & Controls

732-004	GRAY DRIVER INSTRUMENT PANEL		
734-004	GRAY CENTER INSTRUMENT PANEL		
87L-001	ENGINE REMOTE INTERFACE WITH PARK BRAKE INTERLOCK		
870-001	BLACK GAUGE BEZELS		
486-001	LOW AIR PRESSURE INDICATOR LIGHT AND AUDIBLE ALARM		
840-002	2 INCH PRIMARY AND SECONDARY AIR PRESSURE GAUGES		
198-025	INTAKE MOUNTED AIR RESTRICTION INDICATOR WITHOUT GRADUATIONS		
149-013	ELECTRONIC CRUISE CONTROL WITH SWITCHES IN LH SWITCH PANEL		
156-007	KEY OPERATED IGNITION SWITCH AND INTEGRAL START POSITION; 4 POSITION OFF/RUN/START/ACCESSORY		
811-042	ICU3S, 132X48 DISPLAY WITH DIAGNOSTICS, 28 LED WARNING LAMPS AND DATA LINKED		
160-038	HEAVY DUTY ONBOARD DIAGNOSTICS INTERFACE CONNECTOR LOCATED BELOW LH DASH		
844-001	2 INCH ELECTRIC FUEL GAUGE		
148-073	ENGINE REMOTE INTERFACE FOR REMOTE THROTTLE		
163-004	ENGINE REMOTE INTERFACE CONNECTOR IN ENGINE COMPARTMENT		
856-001	ELECTRICAL ENGINE COOLANT TEMPERATURE GAUGE		
864-001	2 INCH TRANSMISSION OIL TEMPERATURE GAUGE		
830-017	ENGINE AND TRIP HOUR METERS INTEGRAL WITHIN DRIVER DISPLAY		

Prepared for:
 Larry Daub
 Super Products Alamo Group
 17000 W Cleveland
 New Berlin, WI 53151
 Phone: 2627847100

Prepared by:
 Tony Bodway
 TRUCK COUNTRY OF
 WISCONSIN, INC.
 2222 WEST RYAN ROAD
 OAK CREEK, WI 53154
 Phone: 414-761-3384

Data Code	Description	Weight Front	Weight Rear
372-051	CUSTOMER FURNISHED AND INSTALLED PTO CONTROLS		
852-002	ELECTRIC ENGINE OIL PRESSURE GAUGE		
746-115	AM/FM/WB WORLD TUNER RADIO WITH BLUETOOTH AND USB AND AUXILIARY INPUTS, J1939	10	
747-001	DASH MOUNTED RADIO		
750-002	(2) RADIO SPEAKERS IN CAB		
753-001	AM/FM ANTENNA MOUNTED ON FORWARD LH ROOF		
810-027	ELECTRONIC MPH SPEEDOMETER WITH SECONDARY KPH SCALE, WITHOUT ODOMETER		
817-001	STANDARD VEHICLE SPEED SENSOR		
812-001	ELECTRONIC 3000 RPM TACHOMETER		
813-998	NO VEHICLE PERFORMANCE MONITOR	-5	
8D1-998	NO DETROIT CONNECT SERVICES SELECTED		
8Z1-998	NO ZONAR SERVICES SELECTED		
162-002	IGNITION SWITCH CONTROLLED ENGINE STOP		
81Y-001	PRE-TRIP LAMP INSPECTION, ALL OUTPUTS FLASH, WITH SMART SWITCH		
836-015	DIGITAL VOLTAGE DISPLAY INTEGRAL WITH DRIVER DISPLAY		
660-008	SINGLE ELECTRIC WINDSHIELD WIPER MOTOR WITH DELAY		
304-001	MARKER LIGHT SWITCH INTEGRAL WITH HEADLIGHT SWITCH		
882-009	ONE VALVE PARKING BRAKE SYSTEM WITH WARNING INDICATOR		
299-013	SELF CANCELING TURN SIGNAL SWITCH WITH DIMMER, WASHER/WIPER AND HAZARD IN HANDLE		
298-039	INTEGRAL ELECTRONIC TURN SIGNAL FLASHER WITH HAZARD LAMPS OVERRIDING STOP LAMPS		

Design

065-000 PAINT: ONE SOLID COLOR

Color

980-5F6 CAB COLOR A: L0006EB WHITE ELITE BC
 986-020 BLACK, HIGH SOLIDS POLYURETHANE CHASSIS PAINT
 98K-998 NO FUEL TANK CABINET PAINT

Prepared for:
 Larry Daub
 Super Products Alamo Group
 17000 W Cleveland
 New Berlin, WI 53151
 Phone: 2627847100

Prepared by:
 Tony Bodway
 TRUCK COUNTRY OF
 WISCONSIN, INC.
 2222 WEST RYAN ROAD
 OAK CREEK, WI 53154
 Phone: 414-761-3384

Data Code	Description	Weight Front	Weight Rear
962-972	POWDER WHITE (N0006EA) FRONT WHEELS/RIMS (PKWHT21, TKWHT21, W, TW)		
966-972	POWDER WHITE (N0006EA) REAR WHEELS/RIMS (PKWHT21, TKWHT21, W, TW)		
963-003	STANDARD E COAT/UNDERCOATING		

Certification / Compliance

996-001	U.S. FMVSS CERTIFICATION, EXCEPT SALES CABS AND GLIDER KITS
---------	---

Secondary Factory Options

82N-998	NO SHIPPING PROTECTION
---------	------------------------

Sales Programs

NO SALES PROGRAMS HAVE BEEN SELECTED

TOTAL VEHICLE SUMMARY

Weight Summary

	Weight Front	Weight Rear	Total Weight
Factory Weight ⁺	9445 lbs	7278 lbs	16723 lbs
Total Weight ⁺	9445 lbs	7278 lbs	16723 lbs

Extended Warranty

WAG-010	TOWING: 1 YEAR/UNLIMITED MILES/KM EXTENDED TOWING COVERAGE \$550 CAP FEX APPLIES
---------	--

(+) Weights shown are estimates only.
 If weight is critical, contact Customer Application Engineering.

Prepared for:
Larry Daub
Super Products Alamo Group
17000 W Cleveland
New Berlin, WI 53151
Phone: 2627847100

Prepared by:
Tony Bodway
TRUCK COUNTRY OF
WISCONSIN, INC.
2222 WEST RYAN ROAD
OAK CREEK, WI 53154
Phone: 414-761-3384

Prepared for:
 Larry Daub
 Super Products Alamo Group
 17000 W Cleveland
 New Berlin, WI 53151
 Phone: 2627847100

Prepared by:
 Tony Bodway
 TRUCK COUNTRY OF
 WISCONSIN, INC.
 2222 WEST RYAN ROAD
 OAK CREEK, WI 53154
 Phone: 414-761-3384

D I M E N S I O N S

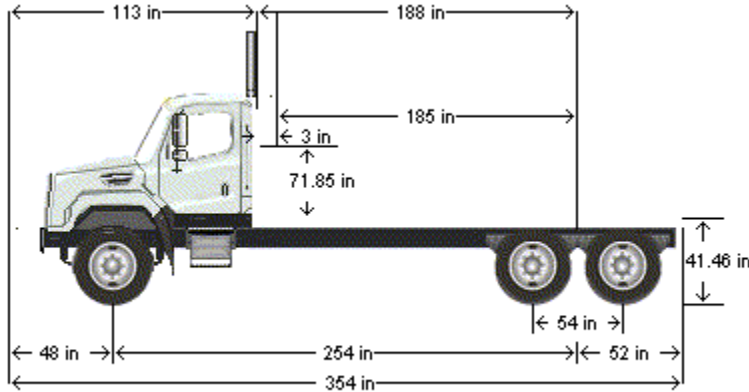

VEHICLE SPECIFICATIONS SUMMARY - DIMENSIONS

Model	114SD
Wheelbase (545)	6450MM (254 INCH) WHEELBASE
Rear Frame Overhang (552)	1325MM (52 INCH) REAR FRAME OVERHANG
Fifth Wheel (578)	NO FIFTH WHEEL
Mounting Location (577)	NO FIFTH WHEEL LOCATION
Maximum Forward Position (in)	0
Maximum Rearward Position (in)	0
Amount of Slide Travel (in)	0
Slide Increment (in)	0
Desired Slide Position (in)	0.0
Cab Size (829)	114 INCH BBC FLAT ROOF ALUMINUM CONVENTIONAL CAB
Sleeper (682)	NO SLEEPER BOX/SLEEPER CAB
Exhaust System (016)	RH OUTBOARD UNDER STEP MOUNTED HORIZONTAL AFTERTREATMENT SYSTEM ASSEMBLY WITH RH B-PILLAR MOUNTED VERTICAL TAILPIPE

TABLE SUMMARY - DIMENSIONS

Prepared for:
 Larry Daub
 Super Products Alamo Group
 17000 W Cleveland
 New Berlin, WI 53151
 Phone: 2627847100

Prepared by:
 Tony Bodway
 TRUCK COUNTRY OF
 WISCONSIN, INC.
 2222 WEST RYAN ROAD
 OAK CREEK, WI 53154
 Phone: 414-761-3384

Dimensions	Inches
Bumper to Back of Cab (BBC)	113.4
Bumper to Centerline of Front Axle (BA)	47.9
Min. Cab to Body Clearance (CB)	3.0
Back of Cab to Centerline of Rear Axle(s) (CA)	188.4
Effective Back of Cab to Centerline of Rear Axle(s) (Effective CA)	185.4
Back of Cab Protrusions (Exhaust/Intake) (CP)	0.0
Back of Cab Protrusions (Side Extenders/Trim Tab) (CP)	0.0
Back of Cab Protrusions (CNG Tank)	0.0
Back of Cab Clearance (CL)	3.0
Back of Cab to End of Frame	240.4
Cab Height (CH)	71.9
Wheelbase (WB)	254.0
Frame Overhang (OH)	52.0
Overall Length (OAL)	353.9
Rear Axle Spacing	54.0
Unladen Frame Height at Centerline of Rear Axle	41.5

Performance calculations are estimates only. If performance calculations are critical, please contact Customer Application Engineering.

Prepared for:
 Larry Daub
 Super Products Alamo Group
 17000 W Cleveland
 New Berlin, WI 53151
 Phone: 2627847100

Prepared by:
 Tony Bodway
 TRUCK COUNTRY OF
 WISCONSIN, INC.
 2222 WEST RYAN ROAD
 OAK CREEK, WI 53154
 Phone: 414-761-3384

FRAME RBM

VEHICLE SPECIFICATIONS SUMMARY - FRAME RBM

Wheelbase (545)6450MM (254 INCH) WHEELBASE
 Frame Rails (546)..... 11/32X3-1/2X10-15/16 INCH STEEL FRAME (8.73MMX277.8MM/0.344X10.94 INCH) 120KSI(546)
 Yield Strength (psi).....120000
 Section Modulus (per rail) (cu in).....16.979
 RBM (per rail) (lbf-in) 2037600
 Inner Frame Reinforcement (547) 1/4 INCH (6.35MM) C-CHANNEL INNER FRAME REINFORCEMENT
 Outer Frame Reinforcement (548) NO OUTER FRAME REINFORCEMENT

TABLE SUMMARY - FRAME RBM

Item	Description / Value
Wheelbase	6450MM (254 INCH) WHEELBASE
Frame	11/32X3-1/2X10-15/16 INCH STEEL FRAME (8.73MMX277.8MM/0.344X10.94 INCH) 120KSI
Inner Frame Reinforcement	1/4 INCH (6.35MM) C-CHANNEL INNER FRAME REINFORCEMENT
Outer Frame Reinforcement	NO OUTER FRAME REINFORCEMENT
Yield Strength (psi)	120000
Section Modulus - per rail (cu. in.)	26.80
Frame RBM - per rail (lbf-in)	3217200

Performance calculations are estimates only. If performance calculations are critical, please contact Customer Application Engineering.

Prepared for:
 Larry Daub
 Super Products Alamo Group
 17000 W Cleveland
 New Berlin, WI 53151
 Phone: 2627847100

Prepared by:
 Tony Bodway
 TRUCK COUNTRY OF
 WISCONSIN, INC.
 2222 WEST RYAN ROAD
 OAK CREEK, WI 53154
 Phone: 414-761-3384

TURNING RADIUS

VEHICLE SPECIFICATIONS SUMMARY - TURNING RADIUS

Model	114SD
Cab Size (829)	114 INCH BBC FLAT ROOF ALUMINUM CONVENTIONAL CAB
Wheelbase (545)	6450MM (254 INCH) WHEELBASE
Front Tires (093)	MICHELIN XZY-3 425/65R22.5 20 PLY RADIAL FRONT TIRES
Width (in)	17.7
Front Axle (400)	DETROIT DA-F-20.0-5 20,000# FL1 71.0 KPI/3.74 DROP SINGLE FRONT AXLE
Kingpin Intersection (in)	71
Bumper (556)	OMIT FRONT BUMPER, CUSTOMER INSTALLED SPECIAL BUMPER, DOES NOT COMPLY WITH FMCSR 393.203
Width (in)	96
Bumper Miter to Front Axle (in)	-9969.42
Primary Steering Location (003)	LH PRIMARY STEERING LOCATION
Steering Gear (536)	TRW THP-60 POWER STEERING WITH RCH45 AUXILIARY GEAR
Dual Steering Gear	RCH45
Ram	NONE
Rear Axle (420)	MT-40-14X 40,000# R-SERIES TANDEM REAR AXLE
Axle Spacing (624)	54 INCH AXLE SPACING

Performance calculations are estimates only. If performance calculations are critical, please contact Customer Application Engineering.