

Prepared for:
Scott Staniszewski
Super Products Alamo Group
17000 W Cleveland
New Berlin, WI 53151
Phone: 2627847100

Prepared by:
Tony Bodway
TRUCK COUNTRY OF
WISCONSIN, INC.
2222 WEST RYAN ROAD
OAK CREEK, WI 53154
Phone: 414-761-3384

A proposal for
Super Products Alamo Group

Prepared by
TRUCK COUNTRY OF WISCONSIN, INC.
Tony Bodway

Jul 03, 2018

Freightliner 114SD

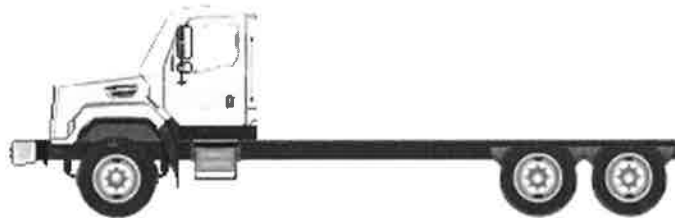

Components shown may not reflect all spec'd options and are not to scale

Prepared for:
 Scott Staniszewski
 Super Products Alamo Group
 17000 W Cleveland
 New Berlin, WI 53151
 Phone: 2627847100

Prepared by:
 Tony Bodway
 TRUCK COUNTRY OF
 WISCONSIN, INC.
 2222 WEST RYAN ROAD
 OAK CREEK, WI 53154
 Phone: 414-761-3384

S P E C I F I C A T I O N P R O P O S A L

Data Code	Description	Weight Front	Weight Rear
Price Level			
PRL-17D	SD PRL-17D (EFF:11/14/17)		
Data Version			
DRL-011	SPECPRO21 DATA RELEASE VER 011		
Vehicle Configuration			
001-177	114SD CONVENTIONAL CHASSIS	7,934	6,576
004-219	2019 MODEL YEAR SPECIFIED		
002-004	SET BACK AXLE - TRUCK	480	-480
019-002	STRAIGHT TRUCK PROVISION		
003-001	LH PRIMARY STEERING LOCATION		
General Service			
AA1-002	TRUCK CONFIGURATION		
AA6-001	DOMICILED, USA 50 STATES (INCLUDING CALIFORNIA AND CARB OPT-IN STATES)		
A85-010	UTILITY/REPAIR/MAINTENANCE SERVICE		
A84-1UT	UTILITY BUSINESS SEGMENT		
AA4-002	LIQUID BULK COMMODITY		
AA5-002	TERRAIN/DUTY: 100% (ALL) OF THE TIME, IN TRANSIT, IS SPENT ON PAVED ROADS		
AB1-008	MAXIMUM 8% EXPECTED GRADE		
AB5-001	SMOOTH CONCRETE OR ASPHALT PAVEMENT - MOST SEVERE IN-TRANSIT (BETWEEN SITES) ROAD SURFACE		
995-1AE	FREIGHTLINER LEVEL II WARRANTY		
A66-99D	EXPECTED FRONT AXLE(S) LOAD : 20000.0 lbs		
A68-99D	EXPECTED REAR DRIVE AXLE(S) LOAD : 40000.0 lbs		
A63-99D	EXPECTED GROSS VEHICLE WEIGHT CAPACITY : 60000.0 lbs		
Truck Service			
AA3-034	SEWER/INDUSTRIAL VACUUM BODY		

Prepared for:
 Scott Staniszewski
 Super Products Alamo Group
 17000 W Cleveland
 New Berlin, WI 53151
 Phone: 2627847100

Prepared by:
 Tony Bodway
 TRUCK COUNTRY OF
 WISCONSIN, INC.
 2222 WEST RYAN ROAD
 OAK CREEK, WI 53154
 Phone: 414-761-3384

Data Code	Description	Weight Front	Weight Rear
AF4-99D	EXPECTED EMPTY BODY WEIGHT : 1350.0 lbs		
A88-99D	EXPECTED TRUCK BODY LENGTH : 1.8 ft		
AE2-99D	EXPECTED TRUCK BODY WIDTH : 89.45 in		
AF3-2AY	SUPER PRODUCTS		
Engine			
101-26P	CUM ISX12N 400 HP @ 1800 RPM, 2100 GOV RPM, 1450 LB/FT @ 1200 RPM	140	-30
Electronic Parameters			
79A-074	74 MPH ROAD SPEED LIMIT		
79B-000	CRUISE CONTROL SPEED LIMIT SAME AS ROAD SPEED LIMIT		
79K-005	PTO MODE ENGINE RPM LIMIT - 900 RPM		
79P-002	PTO RPM WITH CRUISE SET SWITCH - 700 RPM		
79Q-002	PTO RPM WITH CRUISE RESUME SWITCH - 700 RPM		
79S-001	PTO MODE CANCEL VEHICLE SPEED - 5 MPH		
79U-007	PTO GOVERNOR RAMP RATE - 250 RPM PER SECOND		
79V-001	ENABLE REGENERATION IN PTO MODE		
79W-002	TWO REMOTE PTO SPEEDS		
79X-001	PTO SPEED 1 SETTING - 700 RPM		
79Y-001	PTO SPEED 2 SETTING - 900 RPM		
80G-002	PTO MINIMUM RPM - 700		
Engine Equipment			
99C-018	2018 AND LATER NATURAL GAS AND LPG ONLY: 2016 ONBOARD DIAGNOSTICS/2010 EPA/CARB/GHG17		
99D-012	2008 CARB EMISSION CERTIFICATION - EXEMPTED VEHICLE; NO CLEAN IDLE LABEL REQUIRED		
13E-001	STANDARD OIL PAN		
105-001	ENGINE MOUNTED OIL CHECK AND FILL		
014-1B5	SIDE OF HOOD AIR INTAKE WITH DONALDSON HIGH CAPACITY AIR CLEANER WITH SAFETY ELEMENT, FIREWALL MOUNTED		
124-1DJ	DR 12V 160 AMP 36-SI BRUSHLESS QUADRAMOUNT PAD ALTERNATOR WITH REMOTE BATTERY VOLT SENSE	10	
292-098	(2) ALLIANCE MODEL 1231XOE, GROUP 31, 12 VOLT MAINTENANCE FREE 2250 CCA THREADED STUD BATTERIES	-50	-10

Prepared for:
 Scott Staniszewski
 Super Products Alamo Group
 17000 W Cleveland
 New Berlin, WI 53151
 Phone: 2627847100

Prepared by:
 Tony Bodway
 TRUCK COUNTRY OF
 WISCONSIN, INC.
 2222 WEST RYAN ROAD
 OAK CREEK, WI 53154
 Phone: 414-761-3384

Data Code	Description	Weight Front	Weight Rear
290-017	BATTERY BOX FRAME MOUNTED		
281-004	BATTERY JUMPERS WITH MEGA FUSE JUNCTION BLOCK (MFJB)	4	
282-001	SINGLE BATTERY BOX FRAME MOUNTED LH SIDE UNDER CAB		
291-017	WIRE GROUND RETURN FOR BATTERY CABLES WITH ADDITIONAL FRAME GROUND RETURN		
289-001	NON-POLISHED BATTERY BOX COVER		
87P-998	NO CAB AUXILIARY POWER WIRING		
293-058	POSITIVE LOAD DISCONNECT WITH CAB MOUNTED CONTROL SWITCH MOUNTED OUTBOARD DRIVER SEAT	8	
107-032	CUMMINS TURBOCHARGED 18.7 CFM AIR COMPRESSOR WITH INTERNAL SAFETY VALVE		
152-041	ELECTRONIC ENGINE INTEGRAL SHUTDOWN PROTECTION SYSTEM		
016-103	SINGLE HORIZONTAL RH CATALYST WITH CAB MOUNTED VERTICAL TAILPIPE	-160	-80
28F-010	ENGINE AFTERTREATMENT WIRING, OXYGEN SENSOR		
239-014	09 FOOT 06 INCH (114 INCH+0/-5.9 INCH) EXHAUST SYSTEM HEIGHT		
237-1CH	RH CURVED VERTICAL TAILPIPE B-PILLAR MOUNTED ROUTED UNDER FRAME		
23U-998	NO DIESEL EXHAUST FLUID TANK	-60	-35
242-001	STAINLESS STEEL AFTERTREATMENT DEVICE/MUFFLER/TAILPIPE SHIELD		
273-036	BORG WARNER (KYSOR) REAR AIR ON/OFF ENGINE FAN CLUTCH		
276-002	AUTOMATIC FAN CONTROL WITH DASH SWITCH AND INDICATOR LIGHT, NON ENGINE MOUNTED		
118-008	COMBINATION FULL FLOW/BYPASS OIL FILTER		
266-057	1500 SQUARE INCH ALUMINUM RADIATOR		
103-039	ANTIFREEZE TO -34F, OAT (NITRITE AND SILICATE FREE) EXTENDED LIFE COOLANT		
171-007	GATES BLUE STRIPE COOLANT HOSES OR EQUIVALENT		
172-001	CONSTANT TENSION HOSE CLAMPS FOR COOLANT HOSES		
270-016	RADIATOR DRAIN VALVE		
155-058	DELCO 12V 38MT HD STARTER WITH INTEGRATED MAGNETIC SWITCH	-10	

Prepared for:
 Scott Staniszewski
 Super Products Alamo Group
 17000 W Cleveland
 New Berlin, WI 53151
 Phone: 2627847100

Prepared by:
 Tony Bodway
 TRUCK COUNTRY OF
 WISCONSIN, INC.
 2222 WEST RYAN ROAD
 OAK CREEK, WI 53154
 Phone: 414-761-3384

Data Code	Description	Weight Front	Weight Rear
Transmission			
342-1M3	ALLISON 4500 RDS AUTOMATIC TRANSMISSION WITH PTO PROVISION	260	100
Transmission Equipment			
343-338	ALLISON VOCATIONAL PACKAGE 222 - AVAILABLE ON 3000/4000 PRODUCT FAMILIES WITH VOCATIONAL MODEL RDS		
84B-012	ALLISON VOCATIONAL RATING FOR ON/OFF HIGHWAY APPLICATIONS AVAILABLE WITH ALL PRODUCT FAMILIES		
84C-023	PRIMARY MODE GEARS, LOWEST GEAR 1, START GEAR 1, HIGHEST GEAR 6, AVAILABLE FOR 3000/4000 PRODUCT FAMILIES ONLY		
84D-023	SECONDARY MODE GEARS, LOWEST GEAR 1, START GEAR 1, HIGHEST GEAR 6, AVAILABLE FOR 3000/4000 PRODUCT FAMILIES ONLY		
84E-013	S1 PERFORMANCE PRIMARY SHIFT SCHEDULE, AVAILABLE FOR 3000/4000 PRODUCT FAMILIES ONLY		
84F-012	S1 PERFORMANCE SECONDARY SHIFT SCHEDULE, AVAILABLE FOR 3000/4000 PRODUCT FAMILIES ONLY		
84G-011	1950 RPM PRIMARY MODE SHIFT SPEED		
84H-011	1950 RPM SECONDARY MODE SHIFT SPEED		
84L-010	DISABLE - LOAD BASED SHIFT SCHEDULE, DISABLE - VEHICLE ACCELERATION CONTROL		
84N-000	NEUTRAL AT STOP - DISABLED, FUELSENSE - DISABLED		
84U-000	DRIVER SWITCH INPUT - DEFAULT - NO SWITCHES		
353-038	MARKER LAMP CONNECTION FOR BODY BUILDERS		
34C-001	ELECTRONIC TRANSMISSION CUSTOMER ACCESS CONNECTOR FIREWALL MOUNTED		
362-807	CUSTOMER INSTALLED MUNCIE CS41 SERIES PTO		
363-001	PTO MOUNTING, LH SIDE OF MAIN TRANSMISSION		
341-018	MAGNETIC PLUGS, ENGINE DRAIN, TRANSMISSION DRAIN, AXLE(S) FILL AND DRAIN		
345-003	PUSH BUTTON ELECTRONIC SHIFT CONTROL, DASH MOUNTED		
97G-004	TRANSMISSION PROGNOSTICS - ENABLED 2013		

Prepared for:
 Scott Staniszewski
 Super Products Alamo Group
 17000 W Cleveland
 New Berlin, WI 53151
 Phone: 2627847100

Prepared by:
 Tony Bodway
 TRUCK COUNTRY OF
 WISCONSIN, INC.
 2222 WEST RYAN ROAD
 OAK CREEK, WI 53154
 Phone: 414-761-3384

Data Code	Description	Weight Front	Weight Rear
370-011	WATER TO OIL TRANSMISSION COOLER, FRAME MOUNTED		
346-003	TRANSMISSION OIL CHECK AND FILL WITH ELECTRONIC OIL LEVEL CHECK		
35T-001	SYNTHETIC TRANSMISSION FLUID (TES-295 COMPLIANT)		
Front Axle and Equipment			
400-1BB	DETROIT DA-F-20.0-5 20,000# FL1 71.0 KPI/3.74 DROP SINGLE FRONT AXLE	210	
402-030	MERITOR 16.5X6 Q+ CAST SPIDER CAM FRONT BRAKES, DOUBLE ANCHOR, FABRICATED SHOES	10	
403-002	NON-ASBESTOS FRONT BRAKE LINING		
419-014	MERITOR STEELLITE X30 FRONT BRAKE DRUMS	-40	
409-006	FRONT OIL SEALS		
408-001	VENTED FRONT HUB CAPS WITH WINDOW, CENTER AND SIDE PLUGS - OIL		
416-022	STANDARD SPINDLE NUTS FOR ALL AXLES		
405-003	HALDEX AUTOMATIC FRONT SLACK ADJUSTERS		
406-001	STANDARD KING PIN BUSHINGS		
536-055	TRW THP-60 POWER STEERING WITH RCH45 AUXILIARY GEAR	130	
539-003	POWER STEERING PUMP		
534-003	4 QUART POWER STEERING RESERVOIR		
533-001	OIL/AIR POWER STEERING COOLER		
40T-001	ORGANIC SAE 80/90 FRONT AXLE LUBE		
Front Suspension			
620-025	20,000# TAPERLEAF FRONT SUSPENSION	200	
619-004	GRAPHITE BRONZE BUSHINGS WITH SEALS - FRONT SUSPENSION		
410-001	FRONT SHOCK ABSORBERS		
Rear Axle and Equipment			
420-1K3	MT-40-14X 40,000# R-SERIES TANDEM REAR AXLE		-40
421-488	4.88 REAR AXLE RATIO		
424-003	IRON REAR AXLE CARRIER WITH OPTIONAL HEAVY DUTY AXLE HOUSING		40

Prepared for:
 Scott Staniszewski
 Super Products Alamo Group
 17000 W Cleveland
 New Berlin, WI 53151
 Phone: 2627847100

Prepared by:
 Tony Bodway
 TRUCK COUNTRY OF
 WISCONSIN, INC.
 2222 WEST RYAN ROAD
 OAK CREEK, WI 53154
 Phone: 414-761-3384

	Data Code	Description	Weight Front	Weight Rear
N	385-005	DRIVELINE SPACER FOR CUSTOMER FURNISHED EQUIPMENT, TEMPORARILY INSTALLED FOR SHIPPING TO CUSTOMER/TEM	40	40
	386-074	MXL 176T MERITOR EXTENDED LUBE MAIN DRIVELINE WITH HALF ROUND YOKES	45	45
	388-073	MXL 17T MERITOR EXTENDED LUBE INTERAXLE DRIVELINE WITH HALF ROUND YOKES		
	878-019	(1) INTERAXLE LOCK VALVE FOR TANDEM OR TRIDEM DRIVE AXLES		
	87A-001	BLINKING LAMP WITH EACH INTERAXLE LOCK SWITCH, INTERAXLE UNLOCK DEFAULT WITH IGNITION OFF		
	423-020	MERITOR 16.5X7 Q+ CAST SPIDER CAM REAR BRAKES, DOUBLE ANCHOR, FABRICATED SHOES		
	433-002	NON-ASBESTOS REAR BRAKE LINING		
	434-003	STANDARD BRAKE CHAMBER LOCATION		
	451-023	CONMET CAST IRON REAR BRAKE DRUMS		
	440-006	REAR OIL SEALS		
	426-1B3	BENDIX EVERSURE LONGSTROKE 2-DRIVE AXLES SPRING PARKING CHAMBERS		
	428-003	HALDEX AUTOMATIC REAR SLACK ADJUSTERS		
	41T-001	ORGANIC SAE 80/90 REAR AXLE LUBE		
	42T-001	STANDARD REAR AXLE BREATHER(S)		

Rear Suspension

	622-1CH	HENDRICKSON RT403 @40,000# REAR SUSPENSION		670
	621-015	HENDRICKSON RT/RTE - 6.00" SADDLE		
	431-001	STANDARD AXLE SEATS IN AXLE CLAMP GROUP		
	624-009	54 INCH AXLE SPACING		10
	628-004	STEEL BEAMS AND RUBBER CENTER BUSHINGS WITH BAR PIN ADJUSTABLE END CONNECTIONS		
	623-005	FORE/AFT CONTROL RODS		

Brake System

	490-100	WABCO 4S/4M ABS WITHOUT TRACTION CONTROL		
	871-001	REINFORCED NYLON, FABRIC BRAID AND WIRE BRAID CHASSIS AIR LINES		
	904-001	FIBER BRAID PARKING BRAKE HOSE		
	412-001	STANDARD BRAKE SYSTEM VALVES		

Prepared for:
 Scott Staniszewski
 Super Products Alamo Group
 17000 W Cleveland
 New Berlin, WI 53151
 Phone: 2627847100

Prepared by:
 Tony Bodway
 TRUCK COUNTRY OF
 WISCONSIN, INC.
 2222 WEST RYAN ROAD
 OAK CREEK, WI 53154
 Phone: 414-761-3384

Data Code	Description	Weight Front	Weight Rear
46D-002	STANDARD AIR SYSTEM PRESSURE PROTECTION SYSTEM		
413-002	STD U.S. FRONT BRAKE VALVE		
432-003	RELAY VALVE WITH 5-8 PSI CRACK PRESSURE, NO REAR PROPORTIONING VALVE		
480-088	WABCO SYSTEM SAVER HP WITH INTEGRAL AIR GOVERNOR AND HEATER		
* 479-005	AIR DRYER MOUNTED INBOARD ON RH RAIL NO FURTHER BACK OF CAB THAN 24"		
* 460-001	STEEL AIR BRAKE RESERVOIRS 4300 TRIPLE TANK MTD RH AS FAR FWD AS POSSIBLE. REMAINING TNK MTD RH OUTBD, PARALLEL AND LOWERED 50MM, AS FAR AFT AS POSSIBLE. REF HC9318 (DD ENGINE)		
477-001	PULL CABLE ON WET TANK, PETCOCK DRAIN VALVES ON ALL OTHER AIR TANKS		

Trailer Connections

335-004	UPGRADED CHASSIS MULTIPLEXING UNIT		
---------	------------------------------------	--	--

Wheelbase & Frame

	545-695	6950MM (274 INCH) WHEELBASE		
N	546-102	7/16X3-9/16X11-1/8 INCH STEEL FRAME (11.11MMX282.6MM/0.437X11.13 INCH) 120KSI	810	140
	547-001	1/4 INCH (6.35MM) C-CHANNEL INNER FRAME REINFORCEMENT	290	460
	552-017	1475MM (58 INCH) REAR FRAME OVERHANG		
	55W-005	FRAME OVERHANG RANGE: 51 INCH TO 60 INCH	20	-80
*	549-036	12 INCH INTEGRAL FRONT FRAME EXTENSION WITH NO BUMPER NOTCH	80	-10
	AC8-99D	CALC'D BACK OF CAB TO REAR SUSP C/L (CA) : 208.45 in		
	AE8-99D	CALCULATED EFFECTIVE BACK OF CAB TO REAR SUSPENSION C/L (CA) : 182.86 in		
	AE4-99D	CALC'D FRAME LENGTH - OVERALL : 387.01		
	AM6-99D	CALC'D SPACE AVAILABLE FOR DECKPLATE : 208.45 in		
	FSS-0LH	CALCULATED FRAME SPACE LH SIDE : 183.25 in		
	FSS-0RH	CALCULATED FRAME SPACE RH SIDE : 190.84 in		
	553-001	SQUARE END OF FRAME		
	550-001	FRONT CLOSING CROSSMEMBER		
	559-001	STANDARD WEIGHT ENGINE CROSSMEMBER		

Prepared for:
 Scott Staniszewski
 Super Products Alamo Group
 17000 W Cleveland
 New Berlin, WI 53151
 Phone: 2627847100

Prepared by:
 Tony Bodway
 TRUCK COUNTRY OF
 WISCONSIN, INC.
 2222 WEST RYAN ROAD
 OAK CREEK, WI 53154
 Phone: 414-761-3384

Data Code	Description	Weight Front	Weight Rear
562-001	STANDARD MIDSHIP #1 CROSSMEMBER(S)		
572-001	STANDARD REAR MOST CROSSMEMBER		
565-001	STANDARD SUSPENSION CROSSMEMBER		
Chassis Equipment			
556-997	OMIT FRONT BUMPER, CUSTOMER INSTALLED SPECIAL BUMPER, DOES NOT COMPLY WITH FMCSR 393.203	-100	
551-001	HUCK-SPIN ROUND COLLAR CHASSIS FASTENERS SUSPENSIONS ONLY		
606-125	DRLG PREP FOR SUPER PRODUCTS PER DWG 0024917, REV F		
605-103	D15-28195-000 CENTER PUNCH TO MARK CENTERLINE OF REAR SUSPENSION ON TOP FLANGE OF FRAME		
Fuel Tanks			
204-998	NO LH FUEL TANK	-85	-20
230-818	DRG PREP AGILITY 60 DGE CNG FUEL TANKS STACKED BOC, 4X16" DIAMETER, 577MM OAL	925	615
231-008	STACKED TRANSVERSE MOUNTING BACK OF CAB FOR CNG TANKS WITH PAINTED SHIELDING		
664-001	PLAIN STEP FINISH		
220-803	COOLANT HOSES ONLY ROUTED TO BACK OF CAB FOR CUSTOMER INSTALLED NATURAL GAS FUEL HEAT	5	
216-803	CNG INCOMPLETE FUEL LINES FOR TRANSPORT PURPOSES ONLY WITH SINGLE HOSE ROUTED TO LH CHASSIS BACK OF CAB		
11F-998	NO NATURAL GAS VEHICLE FUEL TANK VENT LINE/STACK		
202-020	STAINLESS STEEL AND SYNTHETIC RUBBER FLEXIBLE FUEL LINES - NATURAL GAS SERVICE		
Tires			
093-2CC	MICHELIN XZU-S2 315/80R22.5 20 PLY RADIAL FRONT TIRES	100	
094-1UX	MICHELIN X MULTI D 11R22.5 14 PLY RADIAL REAR TIRES		192
Hubs			
418-058	CONMET PRESET PLUS PREMIUM ALUMINUM FRONT HUBS	-50	
450-060	CONMET PRESET PLUS PREMIUM IRON REAR HUBS		

Prepared for:
 Scott Staniszewski
 Super Products Alamo Group
 17000 W Cleveland
 New Berlin, WI 53151
 Phone: 2627847100

Prepared by:
 Tony Bodway
 TRUCK COUNTRY OF
 WISCONSIN, INC.
 2222 WEST RYAN ROAD
 OAK CREEK, WI 53154
 Phone: 414-761-3384

Data Code	Description	Weight Front	Weight Rear
Wheels			
502-356	ALCOA ULTRA ONE 89U64X 22.5X9.00 10-HUB PILOT 5.99 INSET ALUMINUM FRONT WHEELS	-28	
505-1F2	MAXION WHEELS 90541 22.5X8.25 10-HUB PILOT 6.20 INSET 2-HAND STEEL DISC REAR WHEELS		
524-001	POLISHED FRONT WHEELS; OUTSIDE ONLY		
498-009	WHEEL STUDS FOR CUSTOMER INSTALLED HUB PILOTED DUALED ALUMINUM WHEELS, ALL		
Cab Exterior			
829-1A2	114 INCH BBC FLAT ROOF ALUMINUM CONVENTIONAL CAB		
650-008	AIR CAB MOUNTING		
648-002	NONREMOVABLE BUGSCREEN MOUNTED BEHIND GRILLE		
667-004	FRONT FENDERS SET-BACK AXLE		
678-018	LH AND RH EXTERIOR GRAB HANDLES WITH SINGLE RUBBER INSERT		
645-002	BRIGHT FINISH RADIATOR SHELL/HOOD BEZEL		
646-042	STATIONARY BLACK GRILLE WITH BRIGHT ACCENTS		
65X-003	CHROME HOOD MOUNTED AIR INTAKE GRILLE		
644-004	FIBERGLASS HOOD		
690-017	HOOD LINER, ADDED FIREWALL AND FLOOR HEAT INSULATION	5	
727-1AF	SINGLE 14 INCH ROUND HADLEY AIR HORN UNDER LH DECK		
726-001	SINGLE ELECTRIC HORN		
728-001	SINGLE HORN SHIELD		
657-1CV	DOOR LOCKS AND IGNITION SWITCH KEYED THE SAME WITH (4) KEYS		
575-001	REAR LICENSE PLATE MOUNT END OF FRAME		
312-067	HALOGEN COMPOSITE HEADLAMPS WITH BRIGHT BEZELS		
302-047	LED AERODYNAMIC MARKER LIGHTS		
311-011	DAYTIME RUNNING LIGHTS TO ACTIVATE MARKER, CLEARANCE AND TAIL LIGHTS		
294-046	OMIT STOP/TAIL/BACKUP LIGHTS AND PROVIDE WIRING WITH SEPARATE STOP/TURN WIRES TO 4 FEET BEYOND END OF FRAME		-5
300-015	STANDARD FRONT TURN SIGNAL LAMPS		

Prepared for:
 Scott Staniszewski
 Super Products Alamo Group
 17000 W Cleveland
 New Berlin, WI 53151
 Phone: 2627847100

Prepared by:
 Tony Bodway
 TRUCK COUNTRY OF
 WISCONSIN, INC.
 2222 WEST RYAN ROAD
 OAK CREEK, WI 53154
 Phone: 414-761-3384

Data Code	Description	Weight Front	Weight Rear
744-1BG	DUAL WEST COAST MOLDED-IN COLOR HEATED MIRRORS		
797-001	DOOR MOUNTED MIRRORS		
796-001	102 INCH EQUIPMENT WIDTH		
743-1AP	LH AND RH 8 INCH MOLDED-IN COLOR CONVEX MIRRORS MOUNTED UNDER PRIMARY MIRRORS		
729-001	STANDARD SIDE/REAR REFLECTORS		
768-043	63X14 INCH TINTED REAR WINDOW		
661-003	TINTED DOOR GLASS LH AND RH WITH TINTED NON-OPERATING WING WINDOWS		
654-027	RH AND LH ELECTRIC POWERED WINDOWS, PASSENGER SWITCHES ON DOOR(S)	4	
663-013	TINTED WINDSHIELD		
659-007	8 LITER WINDSHIELD WASHER RESERVOIR, CAB MOUNTED, WITHOUT FLUID LEVEL INDICATOR		
647-001	WHITE WINTERFRONT	2	
Cab Interior			
707-1AK	OPAL GRAY VINYL INTERIOR		
706-026	MOLDED PLASTIC DOOR PANEL WITHOUT VINYL INSERT WITH ALUMINUM KICKPLATE LOWER DOOR		
708-026	MOLDED PLASTIC DOOR PANEL WITHOUT VINYL INSERT WITH ALUMINUM KICKPLATE LOWER DOOR		
772-006	BLACK MATS WITH SINGLE INSULATION		
785-004	DASH MOUNTED ASH TRAY(S) WITHOUT LIGHTER		
691-008	FORWARD ROOF MOUNTED CONSOLE WITH UPPER STORAGE COMPARTMENTS WITHOUT NETTING		
694-010	IN DASH STORAGE BIN		
742-007	(2) CUP HOLDERS LH AND RH DASH		
680-006	GRAY/CHARCOAL FLAT DASH		
720-003	5 LB. FIRE EXTINGUISHER	10	
700-002	HEATER, DEFROSTER AND AIR CONDITIONER		
701-001	STANDARD HVAC DUCTING		
703-005	MAIN HVAC CONTROLS WITH RECIRCULATION SWITCH		
170-015	STANDARD HEATER PLUMBING		

Prepared for:
 Scott Staniszewski
 Super Products Alamo Group
 17000 W Cleveland
 New Berlin, WI 53151
 Phone: 2627847100

Prepared by:
 Tony Bodway
 TRUCK COUNTRY OF
 WISCONSIN, INC.
 2222 WEST RYAN ROAD
 OAK CREEK, WI 53154
 Phone: 414-761-3384

Data Code	Description	Weight Front	Weight Rear
130-033	DENSO HEAVY DUTY AIR CONDITIONER COMPRESSOR		
702-002	BINARY CONTROL, R-134A		
739-034	PREMIUM INSULATION		
285-013	SOLID-STATE CIRCUIT PROTECTION AND FUSES		
280-007	12V NEGATIVE GROUND ELECTRICAL SYSTEM		
324-011	DOMED DOOR ACTIVATED LH AND RH, DUAL READING LIGHTS, FORWARD CAB ROOF		
655-005	LH AND RH ELECTRIC DOOR LOCKS		
284-045	(2) 12 VOLT POWER RECEPTACLES MOUNTED IN DASH		
722-028	TRIANGULAR REFLECTORS KIT WITHOUT FLARES SHIPPED LOOSE IN CAB	10	
756-1J3	BASIC HIGH BACK AIR SUSPENSION DRIVER SEAT WITH MECHANICAL LUMBAR AND INTEGRATED CUSHION EXTENSION	30	
760-1J3	BASIC HIGH BACK AIR SUSPENSION PASSENGER SEAT WITH MECHANICAL LUMBAR AND INTEGRATED CUSHION EXTENSION	25	10
759-005	DUAL DRIVER AND PASSENGER SEAT ARMRESTS	8	
711-004	LH AND RH INTEGRAL DOOR PANEL ARMRESTS		
758-014	BLACK CORDURA PLUS CLOTH DRIVER SEAT COVER		
761-014	BLACK CORDURA PLUS CLOTH PASSENGER SEAT COVER		
763-101	BLACK SEAT BELTS		
532-001	FIXED STEERING COLUMN		
540-015	4-SPOKE 18 INCH (450MM) STEERING WHEEL		
765-002	DRIVER AND PASSENGER INTERIOR SUN VISORS		

Instruments & Controls

732-004	GRAY DRIVER INSTRUMENT PANEL		
734-004	GRAY CENTER INSTRUMENT PANEL		
87L-001	ENGINE REMOTE INTERFACE WITH PARK BRAKE INTERLOCK		
870-001	BLACK GAUGE BEZELS		
486-001	LOW AIR PRESSURE INDICATOR LIGHT AND AUDIBLE ALARM		
840-002	2 INCH PRIMARY AND SECONDARY AIR PRESSURE GAUGES		

Prepared for:
 Scott Staniszewski
 Super Products Alamo Group
 17000 W Cleveland
 New Berlin, WI 53151
 Phone: 2627847100

Prepared by:
 Tony Bodway
 TRUCK COUNTRY OF
 WISCONSIN, INC.
 2222 WEST RYAN ROAD
 OAK CREEK, WI 53154
 Phone: 414-761-3384

Data Code	Description	Weight Front	Weight Rear
198-025	INTAKE MOUNTED AIR RESTRICTION INDICATOR WITHOUT GRADUATIONS		
149-013	ELECTRONIC CRUISE CONTROL WITH SWITCHES IN LH SWITCH PANEL		
156-007	KEY OPERATED IGNITION SWITCH AND INTEGRAL START POSITION; 4 POSITION OFF/RUN/START/ACCESSORY		
811-042	ICU3S, 132X48 DISPLAY WITH DIAGNOSTICS, 28 LED WARNING LAMPS AND DATA LINKED		
160-038	HEAVY DUTY ONBOARD DIAGNOSTICS INTERFACE CONNECTOR LOCATED BELOW LH DASH		
844-001	2 INCH ELECTRIC FUEL GAUGE		
148-073	ENGINE REMOTE INTERFACE FOR REMOTE THROTTLE		
163-001	ENGINE REMOTE INTERFACE CONNECTOR AT BACK OF CAB		
856-001	ELECTRICAL ENGINE COOLANT TEMPERATURE GAUGE		
864-001	2 INCH TRANSMISSION OIL TEMPERATURE GAUGE		
830-017	ENGINE AND TRIP HOUR METERS INTEGRAL WITHIN DRIVER DISPLAY		
372-051	CUSTOMER FURNISHED AND INSTALLED PTO CONTROLS		
852-002	ELECTRIC ENGINE OIL PRESSURE GAUGE		
679-001	OVERHEAD INSTRUMENT PANEL		
746-1B4	AM/FM/WB WORLD TUNER RADIO WITH CD PLAYER, BLUETOOTH, IPOD INTERFACE, USB AND AUXILIARY INPUTS, J1939	10	
747-001	DASH MOUNTED RADIO		
750-002	(2) RADIO SPEAKERS IN CAB		
753-001	AM/FM ANTENNA MOUNTED ON FORWARD LH ROOF		
810-027	ELECTRONIC MPH SPEEDOMETER WITH SECONDARY KPH SCALE, WITHOUT ODOMETER		
817-001	STANDARD VEHICLE SPEED SENSOR		
812-001	ELECTRONIC 3000 RPM TACHOMETER		
813-998	NO VEHICLE PERFORMANCE MONITOR	-5	
162-002	IGNITION SWITCH CONTROLLED ENGINE STOP		
81Y-001	PRE-TRIP LAMP INSPECTION, ALL OUTPUTS FLASH, WITH SMART SWITCH		

Prepared for:
 Scott Staniszewski
 Super Products Alamo Group
 17000 W Cleveland
 New Berlin, WI 53151
 Phone: 2627847100

Prepared by:
 Tony Bodway
 TRUCK COUNTRY OF
 WISCONSIN, INC.
 2222 WEST RYAN ROAD
 OAK CREEK, WI 53154
 Phone: 414-761-3384

Data Code	Description	Weight Front	Weight Rear
836-015	DIGITAL VOLTAGE DISPLAY INTEGRAL WITH DRIVER DISPLAY		
660-008	SINGLE ELECTRIC WINDSHIELD WIPER MOTOR WITH DELAY		
304-001	MARKER LIGHT SWITCH INTEGRAL WITH HEADLIGHT SWITCH		
882-009	ONE VALVE PARKING BRAKE SYSTEM WITH WARNING INDICATOR		
299-013	SELF CANCELING TURN SIGNAL SWITCH WITH DIMMER, WASHER/WIPER AND HAZARD IN HANDLE		
298-039	INTEGRAL ELECTRONIC TURN SIGNAL FLASHER WITH HAZARD LAMPS OVERRIDING STOP LAMPS		

Design

065-000 PAINT: ONE SOLID COLOR

Color

980-5F6 CAB COLOR A: L0006EB WHITE ELITE BC
 986-020 BLACK, HIGH SOLIDS POLYURETHANE CHASSIS PAINT
 98K-5F6 PAINT-FUEL CABINET: L0006EB WHITE ELITE BC
 966-972 POWDER WHITE (N0006EA) REAR WHEELS/RIMS (PKWHT21, TKWHT21, W, TW)
 963-003 STANDARD E COAT/UNDERCOATING

Certification / Compliance

996-001 U.S. FMVSS CERTIFICATION, EXCEPT SALES CABS AND GLIDER KITS

Secondary Factory Options

998-032 CORPORATE PDI CENTER OPTION INSTALLATION/MODIFICATION ONLY

Sales Programs

NO SALES PROGRAMS HAVE BEEN SELECTED

TOTAL VEHICLE SUMMARY

Weight Summary

Weight Front	Weight Rear	Total Weight
--------------	-------------	--------------

Prepared for:
Scott Staniszewski
Super Products Alamo Group
17000 W Cleveland
New Berlin, WI 53151
Phone: 2627847100

Prepared by:
Tony Bodway
TRUCK COUNTRY OF
WISCONSIN, INC.
2222 WEST RYAN ROAD
OAK CREEK, WI 53154
Phone: 414-761-3384

Factory Weight ⁺	11217 lbs	8108 lbs	19325 lbs
<hr/>			
Total Weight ⁺	11217 lbs	8108 lbs	19325 lbs

Extended Warranty

WAG-010 TOWING: 1 YEAR/UNLIMITED MILES/KM EXTENDED TOWING
COVERAGE \$550 CAP FEX APPLIES

(+) Weights shown are estimates only.
If weight is critical, contact Customer Application Engineering.

Prepared for:
 Scott Staniszewski
 Super Products Alamo Group
 17000 W Cleveland
 New Berlin, WI 53151
 Phone: 2627847100

Prepared by:
 Tony Bodway
 TRUCK COUNTRY OF
 WISCONSIN, INC.
 2222 WEST RYAN ROAD
 OAK CREEK, WI 53154
 Phone: 414-761-3384

D I M E N S I O N S

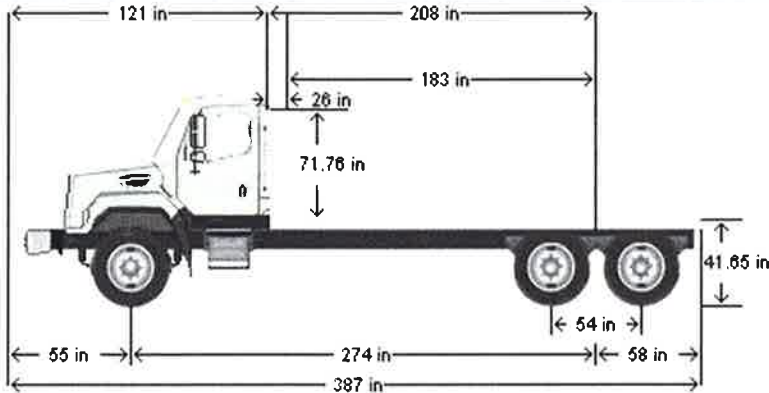

VEHICLE SPECIFICATIONS SUMMARY - DIMENSIONS

Model	114SD
Wheelbase (545)	6950MM (274 INCH) WHEELBASE
Rear Frame Overhang (552)	1475MM (58 INCH) REAR FRAME OVERHANG
Fifth Wheel (578)	NO FIFTH WHEEL
Mounting Location (577)	NO FIFTH WHEEL LOCATION
Maximum Forward Position (in)	0
Maximum Rearward Position (in)	0
Amount of Slide Travel (in)	0
Slide Increment (in)	0
Desired Slide Position (in)	0.0
Cab Size (829)	114 INCH BBC FLAT ROOF ALUMINUM CONVENTIONAL CAB
Sleeper (682)	NO SLEEPER BOX/SLEEPER CAB
Exhaust System (016)	SINGLE HORIZONTAL RH CATALYST WITH CAB MOUNTED VERTICAL TAILPIPE

TABLE SUMMARY - DIMENSIONS

Prepared for:
 Scott Staniszewski
 Super Products Alamo Group
 17000 W Cleveland
 New Berlin, WI 53151
 Phone: 2627847100

Prepared by:
 Tony Bodway
 TRUCK COUNTRY OF
 WISCONSIN, INC.
 2222 WEST RYAN ROAD
 OAK CREEK, WI 53154
 Phone: 414-761-3384

Dimensions	Inches
Bumper to Back of Cab (BBC)	120.9
Bumper to Centerline of Front Axle (BA)	55.3
Min. Cab to Body Clearance (CB)	3.0
Back of Cab to Centerline of Rear Axle(s) (CA)	208.4
Effective Back of Cab to Centerline of Rear Axle(s) (Effective CA)	182.9
Back of Cab Protrusions (Exhaust/Intake) (CP)	2.0
Back of Cab Protrusions (Side Extenders/Trim Tab) (CP)	0.0
Back of Cab Protrusions (CNG Tank)	25.6
Back of Cab Clearance (CL)	25.6
Back of Cab to End of Frame	266.4
Cab Height (CH)	71.8
Wheelbase (WB)	274.0
Frame Overhang (OH)	58.0
Overall Length (OAL)	387.3
Rear Axle Spacing	54.0
Unladen Frame Height at Centerline of Rear Axle	41.6

Performance calculations are estimates only. If performance calculations are critical, please contact Customer Application Engineering.

Prepared for:
 Scott Staniszewski
 Super Products Alamo Group
 17000 W Cleveland
 New Berlin, WI 53151
 Phone: 2627847100

Prepared by:
 Tony Bodway
 TRUCK COUNTRY OF
 WISCONSIN, INC.
 2222 WEST RYAN ROAD
 OAK CREEK, WI 53154
 Phone: 414-761-3384

F R A M E R B M

VEHICLE SPECIFICATIONS SUMMARY - FRAME RBM

Wheelbase (545) 6950MM (274 INCH) WHEELBASE
 Frame Rails (546) 7/16X3-9/16X11-1/8 INCH STEEL FRAME (11.11MMX282.6MM/0.437X11.13 INCH) 120KSI(546)
 Yield Strength (psi) 120000
 Section Modulus (per rail) (cu in) 21.6
 RBM (per rail) (lbf-in) 2592000
 Inner Frame Reinforcement (547) 1/4 INCH (6.35MM) C-CHANNEL INNER FRAME REINFORCEMENT
 Outer Frame Reinforcement (548) NO OUTER FRAME REINFORCEMENT

TABLE SUMMARY - FRAME RBM

Item	Description / Value
Wheelbase	6950MM (274 INCH) WHEELBASE
Frame	7/16X3-9/16X11-1/8 INCH STEEL FRAME (11.11MMX282.6MM/0.437X11.13 INCH) 120KSI
Inner Frame Reinforcement	1/4 INCH (6.35MM) C-CHANNEL INNER FRAME REINFORCEMENT
Outer Frame Reinforcement	NO OUTER FRAME REINFORCEMENT
Yield Strength (psi)	120000
Section Modulus - per rail (cu. in.)	31.00
Frame RBM - per rail (lbf-in)	3715200

Performance calculations are estimates only. If performance calculations are critical, please contact Customer Application Engineering.

Prepared for:
 Scott Staniszewski
 Super Products Alamo Group
 17000 W Cleveland
 New Berlin, WI 53151
 Phone: 2627847100

Prepared by:
 Tony Bodway
 TRUCK COUNTRY OF
 WISCONSIN, INC.
 2222 WEST RYAN ROAD
 OAK CREEK, WI 53154
 Phone: 414-761-3384

TURNING RADIUS



Turning radius graphic and data provided strictly for comparisons between model configurations. Weather, road surfaces, and tire treads affect the results. It is strongly suggested that actual vehicles be measured before constructing any roads/driveways using this information. For specific figures regarding your configuration, please contact your CAE representative.

	Dimensions	Tolerance
Wall to Wall Diameter (ft)	97.0	+/- 3.0
Curb to Curb Diameter (ft)	93.1	+/- 3.0
Turning Radius (ft)	46.0	+/- 1.5

VEHICLE SPECIFICATIONS SUMMARY - TURNING RADIUS

Model..... 114SD
 Cab Size (829) 114 INCH BBC FLAT ROOF ALUMINUM CONVENTIONAL CAB
 Wheelbase (545) 6950MM (274 INCH) WHEELBASE
 Front Tires (093) MICHELIN XZU-S2 315/80R22.5 20 PLY RADIAL FRONT TIRES
 Width (in) 12.5
 Front Axle (400) DETROIT DA-F-20.0-5 20,000# FL1 71.0 KPI/3.74 DROP SINGLE FRONT AXLE
 Kingpin Intersection (in) 71
 Bumper (556) OMIT FRONT BUMPER, CUSTOMER INSTALLED SPECIAL BUMPER, DOES NOT COMPLY WITH FMCSR 393.203
 Width (in) 96
 Bumper Miter to Front Axle (in) 48.017
 Primary Steering Location (003) LH PRIMARY STEERING LOCATION
 Steering Gear (536) TRW THP-60 POWER STEERING WITH RCH45 AUXILIARY GEAR
 Dual Steering Gear RCH45
 Ram NONE
 Rear Axle (420) MT-40-14X 40,000# R-SERIES TANDEM REAR AXLE
 Axle Spacing (624) 54 INCH AXLE SPACING

Performance calculations are estimates only. If performance calculations are critical, please contact Customer Application Engineering.

Prepared for:
Scott Staniszewski
Super Products Alamo Group
17000 W Cleveland
New Berlin, WI 53151
Phone: 2627847100

Prepared by:
Tony Bodway
TRUCK COUNTRY OF
WISCONSIN, INC.
2222 WEST RYAN ROAD
OAK CREEK, WI 53154
Phone: 414-761-3384