

Prepared for:
Scott Staniszewski
Super Products Alamo Group
17000 W Cleveland
New Berlin, WI 53151
Phone: 2627847100

Prepared by:
Tony Bodway
TRUCK COUNTRY OF
WISCONSIN, INC.
2222 WEST RYAN ROAD
OAK CREEK, WI 53154
Phone: 414-761-3384

A proposal for
Super Products Alamo Group

Prepared by
TRUCK COUNTRY OF WISCONSIN, INC.
Tony Bodway

Nov 09, 2018

Freightliner 114SD

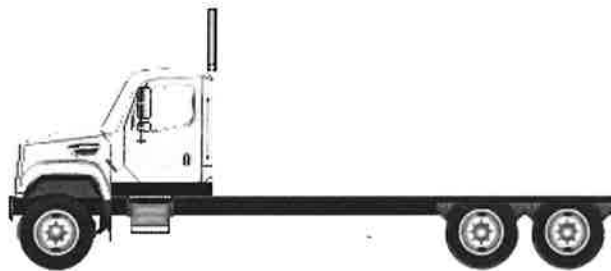

Components shown may not reflect all spec'd options and are not to scale

Prepared for:
 Scott Staniszewski
 Super Products Alamo Group
 17000 W Cleveland
 New Berlin, WI 53151
 Phone: 2627847100

Prepared by:
 Tony Bodway
 TRUCK COUNTRY OF
 WISCONSIN, INC.
 2222 WEST RYAN ROAD
 OAK CREEK, WI 53154
 Phone: 414-761-3384

S P E C I F I C A T I O N P R O P O S A L

Data Code	Description	Weight Front	Weight Rear
Price Level			
PRL-18D	SD PRL-18D (EFF:04/17/18)		
Data Version			
DRL-028	SPECPRO21 DATA RELEASE VER 028		
Vehicle Configuration			
001-177	114SD CONVENTIONAL CHASSIS	7,934	6,576
004-220	2020 MODEL YEAR SPECIFIED		
002-003	SET FORWARD AXLE - TRUCK		
019-002	STRAIGHT TRUCK PROVISION		
003-001	LH PRIMARY STEERING LOCATION		
General Service			
AA1-002	TRUCK CONFIGURATION		
AA6-001	DOMICILED, USA 50 STATES (INCLUDING CALIFORNIA AND CARB OPT-IN STATES)		
A85-010	UTILITY/REPAIR/MAINTENANCE SERVICE		
A84-1UT	UTILITY BUSINESS SEGMENT		
AA4-002	LIQUID BULK COMMODITY		
AA5-002	TERRAIN/DUTY: 100% (ALL) OF THE TIME, IN TRANSIT, IS SPENT ON PAVED ROADS		
AB1-008	MAXIMUM 8% EXPECTED GRADE		
AB5-001	SMOOTH CONCRETE OR ASPHALT PAVEMENT - MOST SEVERE IN-TRANSIT (BETWEEN SITES) ROAD SURFACE		
995-1AE	FREIGHTLINER LEVEL II WARRANTY		
A66-99D	EXPECTED FRONT AXLE(S) LOAD : 20000.0 lbs		
A68-99D	EXPECTED REAR DRIVE AXLE(S) LOAD : 40000.0 lbs		
A63-99D	EXPECTED GROSS VEHICLE WEIGHT CAPACITY : 60000.0 lbs		
Truck Service			
AA3-034	SEWER/INDUSTRIAL VACUUM BODY		

Prepared for:
 Scott Staniszewski
 Super Products Alamo Group
 17000 W Cleveland
 New Berlin, WI 53151
 Phone: 2627847100

Prepared by:
 Tony Bodway
 TRUCK COUNTRY OF
 WISCONSIN, INC.
 2222 WEST RYAN ROAD
 OAK CREEK, WI 53154
 Phone: 414-761-3384

Data Code	Description	Weight Front	Weight Rear
AF3-2AY	SUPER PRODUCTS		
Engine			
101-2X9	DETROIT DD13 12.8L 450 HP @ 1625 RPM, 1900 GOV RPM, 1550 LB/FT @ 975 RPM		
Electronic Parameters			
79A-073	73 MPH ROAD SPEED LIMIT		
79B-000	CRUISE CONTROL SPEED LIMIT SAME AS ROAD SPEED LIMIT		
79K-005	PTO MODE ENGINE RPM LIMIT - 900 RPM		
79P-002	PTO RPM WITH CRUISE SET SWITCH - 700 RPM		
79Q-002	PTO RPM WITH CRUISE RESUME SWITCH - 700 RPM		
79R-001	PTO MODE COOLING FAN ENABLE		
79S-001	PTO MODE CANCEL VEHICLE SPEED - 5 MPH		
79T-001	PTO MODE RPM INCREMENT - 25 RPM		
79U-006	PTO GOVERNOR RAMP RATE - 200 RPM PER SECOND		
79V-001	FUEL DOSING OF AFTERTREATMENT ENABLED IN PTO MODE-CLEANS HYDROCARBONS AT HIGH TEMPERATURES ONLY		
79W-002	TWO REMOTE PTO SPEEDS		
79X-001	PTO SPEED 1 SETTING - 700 RPM		
79Y-001	PTO SPEED 2 SETTING - 900 RPM		
80G-002	PTO MINIMUM RPM - 700		
80L-003	ENABLE DPF REGEN ZONE 1 WITH AUTO ENGINE RPM ELEVATE FOR EXTENDED IDLE		
Engine Equipment			
99C-017	2016 ONBOARD DIAGNOSTICS/2010 EPA/CARB/FINAL GHG17 CONFIGURATION		
99D-011	2008 CARB EMISSION CERTIFICATION - CLEAN IDLE (INCLUDES 6X4 INCH LABEL ON LOWER FORWARD CORNER OF DRIVER DOOR)		
13E-001	STANDARD OIL PAN		
105-001	ENGINE MOUNTED OIL CHECK AND FILL		
014-1B5	SIDE OF HOOD AIR INTAKE WITH DONALDSON HIGH CAPACITY AIR CLEANER WITH SAFETY ELEMENT, FIREWALL MOUNTED		
124-1D7	DR 12V 160 AMP 28-SI QUADRAMOUNT PAD ALTERNATOR WITH REMOTE BATTERY VOLT SENSE		

Prepared for:
 Scott Staniszewski
 Super Products Alamo Group
 17000 W Cleveland
 New Berlin, WI 53151
 Phone: 2627847100

Prepared by:
 Tony Bodway
 TRUCK COUNTRY OF
 WISCONSIN, INC.
 2222 WEST RYAN ROAD
 OAK CREEK, WI 53154
 Phone: 414-761-3384

Data Code	Description	Weight Front	Weight Rear
292-209	(3) DTNA GENUINE, FLOODED STARTING, MIN 3375CCA, 585RC, THREADED STUD BATTERIES		
290-017	BATTERY BOX FRAME MOUNTED		
281-004	BATTERY JUMPERS WITH MEGA FUSE JUNCTION BLOCK (MFJB)	4	
282-001	SINGLE BATTERY BOX FRAME MOUNTED LH SIDE UNDER CAB		
291-017	WIRE GROUND RETURN FOR BATTERY CABLES WITH ADDITIONAL FRAME GROUND RETURN		
289-001	NON-POLISHED BATTERY BOX COVER		
87P-998	NO CAB AUXILIARY POWER WIRING		
293-058	POSITIVE LOAD DISCONNECT WITH CAB MOUNTED CONTROL SWITCH MOUNTED OUTBOARD DRIVER SEAT	8	
295-029	POSITIVE AND NEGATIVE POSTS FOR JUMPSTART LOCATED ON FRAME NEXT TO STARTER	2	
107-044	BW MODEL BA-921 19.0 CFM SINGLE CYLINDER AIR COMPRESSOR WITH SAFETY VALVE		
152-041	ELECTRONIC ENGINE INTEGRAL SHUTDOWN PROTECTION SYSTEM		
128-002	JACOBS COMPRESSION BRAKE		
016-1C2	RH OUTBOARD UNDER STEP MOUNTED HORIZONTAL AFTERTREATMENT SYSTEM ASSEMBLY WITH RH B-PILLAR MOUNTED VERTICAL TAILPIPE	30	25
28F-007	ENGINE AFTERTREATMENT DEVICE, AUTOMATIC OVER THE ROAD ACTIVE REGENERATION AND DASH MOUNTED SINGLE REGENERATION REQUEST/INHIBIT SWITCH		
239-200	INTEGRATED STACK AND B-PILLAR PIPE WITH MINIMUM STACK PROTRUSION ABOVE CAB		
237-1CR	RH CURVED VERTICAL TAILPIPE B-PILLAR MOUNTED ROUTED FROM STEP		
23U-002	13 GALLON DIESEL EXHAUST FLUID TANK		
30N-003	100 PERCENT DIESEL EXHAUST FLUID FILL		
23Y-001	STANDARD DIESEL EXHAUST FLUID PUMP MOUNTING		
43X-002	LH MEDIUM DUTY STANDARD DIESEL EXHAUST FLUID TANK LOCATION		
43Y-001	STANDARD DIESEL EXHAUST FLUID TANK CAP		
242-011	ALUMINUM AFTERTREATMENT DEVICE/MUFFLER/TAILPIPE SHIELD(S)		
273-036	BORG WARNER (KYSOR) REAR AIR ON/OFF ENGINE FAN CLUTCH		

Prepared for:
 Scott Staniszewski
 Super Products Alamo Group
 17000 W Cleveland
 New Berlin, WI 53151
 Phone: 2627847100

Prepared by:
 Tony Bodway
 TRUCK COUNTRY OF
 WISCONSIN, INC.
 2222 WEST RYAN ROAD
 OAK CREEK, WI 53154
 Phone: 414-761-3384

Data Code	Description	Weight Front	Weight Rear
276-002	AUTOMATIC FAN CONTROL WITH DASH SWITCH AND INDICATOR LIGHT, NON ENGINE MOUNTED		
110-068	DDC SUPPLIED ENGINE MOUNTED FUEL FILTER/FUEL WATER SEPARATOR WITH WATER-IN-FUEL INDICATOR		
118-001	FULL FLOW OIL FILTER		
266-057	1500 SQUARE INCH ALUMINUM RADIATOR		
103-039	ANTIFREEZE TO -34F, OAT (NITRITE AND SILICATE FREE) EXTENDED LIFE COOLANT		
171-007	GATES BLUE STRIPE COOLANT HOSES OR EQUIVALENT		
172-001	CONSTANT TENSION HOSE CLAMPS FOR COOLANT HOSES		
270-023	HDEP FIXED RATIO COOLANT PUMP AND RADIATOR DRAIN VALVE		
138-005	PHILLIPS-TEMRO 1500 WATT/115 VOLT BLOCK HEATER	4	
140-053	BLACK PLASTIC ENGINE HEATER RECEPTACLE MOUNTED UNDER LH DOOR		
155-075	MITSUBISHI 12V MOD 3.175-DP60 STARTER WITH INTEGRATED MAGNETIC SWITCH		

Transmission

342-1M1	ALLISON 4000 RDS AUTOMATIC TRANSMISSION WITH PTO PROVISION	260	100
---------	--	-----	-----

Transmission Equipment

343-338	ALLISON VOCATIONAL PACKAGE 222 - AVAILABLE ON 3000/4000 PRODUCT FAMILIES WITH VOCATIONAL MODEL RDS		
84B-012	ALLISON VOCATIONAL RATING FOR ON/OFF HIGHWAY APPLICATIONS AVAILABLE WITH ALL PRODUCT FAMILIES		
84C-023	PRIMARY MODE GEARS, LOWEST GEAR 1, START GEAR 1, HIGHEST GEAR 6, AVAILABLE FOR 3000/4000 PRODUCT FAMILIES ONLY		
84D-023	SECONDARY MODE GEARS, LOWEST GEAR 1, START GEAR 1, HIGHEST GEAR 6, AVAILABLE FOR 3000/4000 PRODUCT FAMILIES ONLY		
84E-013	S1 PERFORMANCE PRIMARY SHIFT SCHEDULE, AVAILABLE FOR 3000/4000 PRODUCT FAMILIES ONLY		
84F-012	S1 PERFORMANCE SECONDARY SHIFT SCHEDULE, AVAILABLE FOR 3000/4000 PRODUCT FAMILIES ONLY		
84G-009	1800 RPM PRIMARY MODE SHIFT SPEED		

Prepared for:
 Scott Staniszewski
 Super Products Alamo Group
 17000 W Cleveland
 New Berlin, WI 53151
 Phone: 2627847100

Prepared by:
 Tony Bodway
 TRUCK COUNTRY OF
 WISCONSIN, INC.
 2222 WEST RYAN ROAD
 OAK CREEK, WI 53154
 Phone: 414-761-3384

Data Code	Description	Weight Front	Weight Rear
84H-009	1800 RPM SECONDARY MODE SHIFT SPEED		
84L-010	DISABLE - LOAD BASED SHIFT SCHEDULE, DISABLE - VEHICLE ACCELERATION CONTROL		
84N-000	NEUTRAL AT STOP - DISABLED, FUELSENSE - DISABLED		
84U-000	DRIVER SWITCH INPUT - DEFAULT - NO SWITCHES		
353-038	MARKER LAMP CONNECTION FOR BODY BUILDERS		
34C-001	ELECTRONIC TRANSMISSION CUSTOMER ACCESS CONNECTOR FIREWALL MOUNTED		
362-807	CUSTOMER INSTALLED MUNCIE CS41 SERIES PTO		
363-001	PTO MOUNTING, LH SIDE OF MAIN TRANSMISSION		
341-018	MAGNETIC PLUGS, ENGINE DRAIN, TRANSMISSION DRAIN, AXLE(S) FILL AND DRAIN		
345-003	PUSH BUTTON ELECTRONIC SHIFT CONTROL, DASH MOUNTED		
97G-004	TRANSMISSION PROGNOSTICS - ENABLED 2013		
370-011	WATER TO OIL TRANSMISSION COOLER, FRAME MOUNTED		
346-003	TRANSMISSION OIL CHECK AND FILL WITH ELECTRONIC OIL LEVEL CHECK		
35T-001	SYNTHETIC TRANSMISSION FLUID (TES-295 COMPLIANT)		

Front Axle and Equipment

400-1BB	DETROIT DA-F-20.0-5 20,000# FL1 71.0 KPI/3.74 DROP SINGLE FRONT AXLE	210	
402-030	MERITOR 16.5X6 Q+ CAST SPIDER CAM FRONT BRAKES, DOUBLE ANCHOR, FABRICATED SHOES	10	
403-002	NON-ASBESTOS FRONT BRAKE LINING		
419-014	MERITOR STEELLITE X30 FRONT BRAKE DRUMS	-40	
409-006	FRONT OIL SEALS		
408-001	VENTED FRONT HUB CAPS WITH WINDOW, CENTER AND SIDE PLUGS - OIL		
416-022	STANDARD SPINDLE NUTS FOR ALL AXLES		
405-003	HALDEX AUTOMATIC FRONT SLACK ADJUSTERS		
406-001	STANDARD KING PIN BUSHINGS		

Prepared for:
 Scott Staniszewski
 Super Products Alamo Group
 17000 W Cleveland
 New Berlin, WI 53151
 Phone: 2627847100

Prepared by:
 Tony Bodway
 TRUCK COUNTRY OF
 WISCONSIN, INC.
 2222 WEST RYAN ROAD
 OAK CREEK, WI 53154
 Phone: 414-761-3384

Data Code	Description	Weight Front	Weight Rear
536-055	TRW THP-60 POWER STEERING WITH RCH45 AUXILIARY GEAR	130	
539-003	POWER STEERING PUMP		
534-003	4 QUART POWER STEERING RESERVOIR		
533-001	OIL/AIR POWER STEERING COOLER		
40T-001	ORGANIC SAE 80/90 FRONT AXLE LUBE		
Front Suspension			
620-025	20,000# TAPERLEAF FRONT SUSPENSION	200	
619-004	GRAPHITE BRONZE BUSHINGS WITH SEALS - FRONT SUSPENSION		
410-001	FRONT SHOCK ABSORBERS		
Rear Axle and Equipment			
420-1K3	MT-40-14X 40,000# R-SERIES TANDEM REAR AXLE		-40
421-433	4.33 REAR AXLE RATIO		
424-003	IRON REAR AXLE CARRIER WITH OPTIONAL HEAVY DUTY AXLE HOUSING		40
385-005	DRIVELINE SPACER FOR CUSTOMER FURNISHED EQUIPMENT	40	40
REF SUPER PRODUCTS "CAMEL 1200" WORKSHEET			
386-074	MXL 176T MERITOR EXTENDED LUBE MAIN DRIVELINE WITH HALF ROUND YOKES	45	45
388-073	MXL 17T MERITOR EXTENDED LUBE INTERAXLE DRIVELINE WITH HALF ROUND YOKES		
878-019	(1) INTERAXLE LOCK VALVE FOR TANDEM OR TRIDEM DRIVE AXLES		
87A-001	BLINKING LAMP WITH EACH INTERAXLE LOCK SWITCH, INTERAXLE UNLOCK DEFAULT WITH IGNITION OFF		
423-020	MERITOR 16.5X7 Q+ CAST SPIDER CAM REAR BRAKES, DOUBLE ANCHOR, FABRICATED SHOES		
433-002	NON-ASBESTOS REAR BRAKE LINING		
434-003	STANDARD BRAKE CHAMBER LOCATION		
451-023	CONMET CAST IRON REAR BRAKE DRUMS		
440-006	REAR OIL SEALS		
426-1B3	BENDIX EVERSURE LONGSTROKE 2-DRIVE AXLES SPRING PARKING CHAMBERS		
428-003	HALDEX AUTOMATIC REAR SLACK ADJUSTERS		
41T-001	ORGANIC SAE 80/90 REAR AXLE LUBE		
42T-001	STANDARD REAR AXLE BREATHER(S)		

Prepared for:
 Scott Staniszewski
 Super Products Alamo Group
 17000 W Cleveland
 New Berlin, WI 53151
 Phone: 2627847100

Prepared by:
 Tony Bodway
 TRUCK COUNTRY OF
 WISCONSIN, INC.
 2222 WEST RYAN ROAD
 OAK CREEK, WI 53154
 Phone: 414-761-3384

Data Code	Description	Weight Front	Weight Rear
Rear Suspension			
622-1CH	HENDRICKSON RT403 @40,000# REAR SUSPENSION		670
621-015	HENDRICKSON RT/RTE - 6.00" SADDLE		
431-001	STANDARD AXLE SEATS IN AXLE CLAMP GROUP		
624-009	54 INCH AXLE SPACING		10
628-004	STEEL BEAMS AND RUBBER CENTER BUSHINGS WITH BAR PIN ADJUSTABLE END CONNECTIONS		
623-005	FORE/AFT CONTROL RODS		
Brake System			
490-100	WABCO 4S/4M ABS		
871-001	REINFORCED NYLON, FABRIC BRAID AND WIRE BRAID CHASSIS AIR LINES		
904-001	FIBER BRAID PARKING BRAKE HOSE		
412-001	STANDARD BRAKE SYSTEM VALVES		
46D-002	STANDARD AIR SYSTEM PRESSURE PROTECTION SYSTEM		
413-002	STD U.S. FRONT BRAKE VALVE		
432-003	RELAY VALVE WITH 5-8 PSI CRACK PRESSURE, NO REAR PROPORTIONING VALVE		
480-009	BW AD-9 BRAKE LINE AIR DRYER WITH HEATER	20	
483-003	BENDIX OIL COALESCING FILTER FOR AIR DRYER		
• 479-007	AIR DRYER MOUNTED OUTBOARD ON RH RAIL BACK OF CAB REF JM4977		
• 460-001	STEEL AIR BRAKE RESERVOIRS 4300 TRIPLE TANK MTD RH AS FAR FWD AS POSSIBLE. REMAINING TNK MTD RH OUTBD, PARALLEL AND LOWERED 50MM, AS FAR AFT AS POSSIBLE. REF JM4977 (DD ENGINE)		
477-001	PULL CABLE ON WET TANK, PETCOCK DRAIN VALVES ON ALL OTHER AIR TANKS		
Trailer Connections			
335-004	UPGRADED CHASSIS MULTIPLEXING UNIT		
Wheelbase & Frame			
545-690	6900MM (272 INCH) WHEELBASE		
546-102	7/16X3-9/16X11-1/8 INCH STEEL FRAME (11.11MMX282.6MM/0.437X11.13 INCH) 120KSI	810	140
547-001	1/4 INCH (6.35MM) C-CHANNEL INNER FRAME REINFORCEMENT	240	460

Prepared for:
 Scott Staniszewski
 Super Products Alamo Group
 17000 W Cleveland
 New Berlin, WI 53151
 Phone: 2627847100

Prepared by:
 Tony Bodway
 TRUCK COUNTRY OF
 WISCONSIN, INC.
 2222 WEST RYAN ROAD
 OAK CREEK, WI 53154
 Phone: 414-761-3384

Data Code	Description	Weight Front	Weight Rear
552-023	1325MM (52 INCH) REAR FRAME OVERHANG		
55W-005	FRAME OVERHANG RANGE: 51 INCH TO 60 INCH	20	-80
* 549-095	12 INCH INTEGRAL FRONT FRAME EXTENSION WITH NO BUMPER NOTCH AND 0.25" INSERT		
AC8-99D	CALC'D BACK OF CAB TO REAR SUSP C/L (CA) : 188.54 in		
AE8-99D	CALCULATED EFFECTIVE BACK OF CAB TO REAR SUSPENSION C/L (CA) : 185.54 in		
AE4-99D	CALC'D FRAME LENGTH - OVERALL : 340.87		
AM6-99D	CALC'D SPACE AVAILABLE FOR DECKPLATE : 188.54 in		
FSS-0LH	CALCULATED FRAME SPACE LH SIDE : 100.6 in		
FSS-0RH	CALCULATED FRAME SPACE RH SIDE : 156.68 in		
553-001	SQUARE END OF FRAME		
550-001	FRONT CLOSING CROSSMEMBER		
559-001	STANDARD WEIGHT ENGINE CROSSMEMBER		
* 562-341	STANDARD MIDSHIP #1 CROSSMEMBER MOUNTED 1035MM (41 INCH) FROM BACK OF CAB		
* 563-326	MIDSHIP #2 CROSSMEMBER MOUNTED 650MM (26") FROM MIDSHIP #1		
	OMIT 564		
* 572-072	STANDARD REARMOST CROSSMEMBER MOUNTED 975MM AFT OF REAR SUSPENSION CENTERLINE		
565-001	STANDARD SUSPENSION CROSSMEMBER		
Chassis Equipment			
556-997	OMIT FRONT BUMPER, CUSTOMER INSTALLED SPECIAL BUMPER, DOES NOT COMPLY WITH FMCSR 393.203	-100	
551-001	HUCK-SPIN ROUND COLLAR CHASSIS FASTENERS SUSPENSIONS ONLY		
* 606-125	DRLG PREP FOR SUPER PRODUCTS PER DWG 0024917, REV 3		
605-103	D15-28195-000 CENTER PUNCH TO MARK CENTERLINE OF REAR SUSPENSION ON TOP FLANGE OF FRAME		
Fuel Tanks			
204-156	100 GALLON/378 LITER ALUMINUM FUEL TANK - LH	20	
218-006	25 INCH DIAMETER FUEL TANK(S)		

Prepared for:
 Scott Staniszewski
 Super Products Alamo Group
 17000 W Cleveland
 New Berlin, WI 53151
 Phone: 2627847100

Prepared by:
 Tony Bodway
 TRUCK COUNTRY OF
 WISCONSIN, INC.
 2222 WEST RYAN ROAD
 OAK CREEK, WI 53154
 Phone: 414-761-3384

Data Code	Description	Weight Front	Weight Rear
215-005	PLAIN ALUMINUM/PAINTED STEEL FUEL/HYDRAULIC TANK(S) WITH PAINTED BANDS		
212-007	FUEL TANK(S) FORWARD		
664-001	PLAIN STEP FINISH		
205-001	FUEL TANK CAP(S)		
216-020	EQUIFLO INBOARD FUEL SYSTEM		
11F-998	NO NATURAL GAS VEHICLE FUEL TANK VENT LINE/STACK		
202-016	HIGH TEMPERATURE REINFORCED NYLON FUEL LINE		
Tires			
093-0TB	MICHELIN XZY-3 425/65R22.5 20 PLY RADIAL FRONT TIRES	196	
094-1UX	MICHELIN X MULTI D 11R22.5 14 PLY RADIAL REAR TIRES		192
Hubs			
418-058	CONMET PRESET PLUS PREMIUM ALUMINUM FRONT HUBS	-50	
450-060	CONMET PRESET PLUS PREMIUM IRON REAR HUBS		
Wheels			
502-1H5	ALCOA LVL ONE 82462X 22.5X12.25 10-HUB PILOT 4.68 INSET 10-HAND ALUMINUM DISC FRONT WHEELS	-8	
505-1F2	MAXION WHEELS 90541 22.5X8.25 10-HUB PILOT 6.20 INSET 2-HAND STEEL DISC REAR WHEELS		
524-001	POLISHED FRONT WHEELS; OUTSIDE ONLY		
498-009	WHEEL STUDS FOR CUSTOMER INSTALLED HUB PILOTED DUALED ALUMINUM WHEELS, ALL		
Cab Exterior			
829-1A2	114 INCH BBC FLAT ROOF ALUMINUM CONVENTIONAL CAB		
650-008	AIR CAB MOUNTING		
648-002	NONREMOVABLE BUGSCREEN MOUNTED BEHIND GRILLE		
667-001	FRONT FENDERS		
754-002	3-1/2 INCH FENDER EXTENSIONS	15	
678-018	LH AND RH EXTERIOR GRAB HANDLES WITH SINGLE RUBBER INSERT		

Prepared for:
 Scott Staniszewski
 Super Products Alamo Group
 17000 W Cleveland
 New Berlin, WI 53151
 Phone: 2627847100

Prepared by:
 Tony Bodway
 TRUCK COUNTRY OF
 WISCONSIN, INC.
 2222 WEST RYAN ROAD
 OAK CREEK, WI 53154
 Phone: 414-761-3384

Data Code	Description	Weight Front	Weight Rear
645-002	BRIGHT FINISH RADIATOR SHELL/HOOD BEZEL		
646-042	STATIONARY BLACK GRILLE WITH BRIGHT ACCENTS		
65X-003	CHROME HOOD MOUNTED AIR INTAKE GRILLE		
644-004	FIBERGLASS HOOD		
690-007	HOOD LINER INSULATION WITH SINGLE FIREWALL INSULATION		
727-1AF	SINGLE 14 INCH ROUND HADLEY AIR HORN UNDER LH DECK		
726-001	SINGLE ELECTRIC HORN		
728-001	SINGLE HORN SHIELD		
657-1CV	DOOR LOCKS AND IGNITION SWITCH KEYED THE SAME WITH (4) KEYS		
575-001	REAR LICENSE PLATE MOUNT END OF FRAME		
312-067	HALOGEN COMPOSITE HEADLAMPS WITH BRIGHT BEZELS		
302-047	LED AERODYNAMIC MARKER LIGHTS		
311-012	DAYTIME RUNNING LIGHTS - LOW BEAM ONLY		
294-046	OMIT STOP/TAIL/BACKUP LIGHTS AND PROVIDE WIRING WITH SEPARATE STOP/TURN WIRES TO 4 FEET BEYOND END OF FRAME		-5
300-015	STANDARD FRONT TURN SIGNAL LAMPS		
744-1BG	DUAL WEST COAST MOLDED-IN COLOR HEATED MIRRORS		
797-001	DOOR MOUNTED MIRRORS		
796-001	102 INCH EQUIPMENT WIDTH		
743-1AP	LH AND RH 8 INCH MOLDED-IN COLOR CONVEX MIRRORS MOUNTED UNDER PRIMARY MIRRORS		
729-001	STANDARD SIDE/REAR REFLECTORS		
677-054	RH AFTERTREATMENT SYSTEM CAB ACCESS WITH PLAIN DIAMOND PLATE COVER		
768-043	63X14 INCH TINTED REAR WINDOW		
661-003	TINTED DOOR GLASS LH AND RH WITH TINTED NON-OPERATING WING WINDOWS		
654-027	RH AND LH ELECTRIC POWERED WINDOWS, PASSENGER SWITCHES ON DOOR(S)	4	
663-013	TINTED WINDSHIELD		
659-007	8 LITER WINDSHIELD WASHER RESERVOIR, CAB MOUNTED, WITHOUT FLUID LEVEL INDICATOR		

Cab Interior

Prepared for:
 Scott Staniszewski
 Super Products Alamo Group
 17000 W Cleveland
 New Berlin, WI 53151
 Phone: 2627847100

Prepared by:
 Tony Bodway
 TRUCK COUNTRY OF
 WISCONSIN, INC.
 2222 WEST RYAN ROAD
 OAK CREEK, WI 53154
 Phone: 414-761-3384

Data Code	Description	Weight Front	Weight Rear
707-1AK	OPAL GRAY VINYL INTERIOR		
706-026	MOLDED PLASTIC DOOR PANEL WITHOUT VINYL INSERT WITH ALUMINUM KICKPLATE LOWER DOOR		
708-026	MOLDED PLASTIC DOOR PANEL WITHOUT VINYL INSERT WITH ALUMINUM KICKPLATE LOWER DOOR		
772-006	BLACK MATS WITH SINGLE INSULATION		
785-004	DASH MOUNTED ASH TRAY(S) WITHOUT LIGHTER		
691-008	FORWARD ROOF MOUNTED CONSOLE WITH UPPER STORAGE COMPARTMENTS WITHOUT NETTING		
694-010	IN DASH STORAGE BIN		
696-012	CENTER STORAGE CONSOLE MOUNTED ON BACKWALL	20	
742-007	(2) CUP HOLDERS LH AND RH DASH		
680-006	GRAY/CHARCOAL FLAT DASH		
720-003	5 LB. FIRE EXTINGUISHER	10	
700-002	HEATER, DEFROSTER AND AIR CONDITIONER		
701-001	STANDARD HVAC DUCTING		
703-005	MAIN HVAC CONTROLS WITH RECIRCULATION SWITCH		
170-015	STANDARD HEATER PLUMBING		
130-033	DENSO HEAVY DUTY AIR CONDITIONER COMPRESSOR		
702-002	BINARY CONTROL, R-134A		
739-033	STANDARD INSULATION		
285-013	SOLID-STATE CIRCUIT PROTECTION AND FUSES		
280-007	12V NEGATIVE GROUND ELECTRICAL SYSTEM		
324-014	DOMELIGHT WITH 3-WAY SWITCH ACTIVATED BY LH AND RH DOORS		
655-005	LH AND RH ELECTRIC DOOR LOCKS		
284-045	(2) 12 VOLT POWER RECEPTACLES MOUNTED IN DASH		
722-028	TRIANGULAR REFLECTORS KIT WITHOUT FLARES SHIPPED LOOSE IN CAB	10	
756-1J3	BASIC HIGH BACK AIR SUSPENSION DRIVER SEAT WITH MECHANICAL LUMBAR AND INTEGRATED CUSHION EXTENSION	30	

Prepared for:
 Scott Staniszewski
 Super Products Alamo Group
 17000 W Cleveland
 New Berlin, WI 53151
 Phone: 2627847100

Prepared by:
 Tony Bodway
 TRUCK COUNTRY OF
 WISCONSIN, INC.
 2222 WEST RYAN ROAD
 OAK CREEK, WI 53154
 Phone: 414-761-3384

Data Code	Description	Weight Front	Weight Rear
760-1J3	BASIC HIGH BACK AIR SUSPENSION PASSENGER SEAT WITH MECHANICAL LUMBAR AND INTEGRATED CUSHION EXTENSION	25	10
759-005	DUAL DRIVER AND PASSENGER SEAT ARMRESTS	8	
711-004	LH AND RH INTEGRAL DOOR PANEL ARMRESTS		
758-014	BLACK CORDURA PLUS CLOTH DRIVER SEAT COVER		
761-014	BLACK CORDURA PLUS CLOTH PASSENGER SEAT COVER		
763-101	BLACK SEAT BELTS		
532-001	FIXED STEERING COLUMN		
540-015	4-SPOKE 18 INCH (450MM) STEERING WHEEL		
765-002	DRIVER AND PASSENGER INTERIOR SUN VISORS		

Instruments & Controls

732-004	GRAY DRIVER INSTRUMENT PANEL
734-004	GRAY CENTER INSTRUMENT PANEL
87L-001	ENGINE REMOTE INTERFACE WITH PARK BRAKE INTERLOCK
870-001	BLACK GAUGE BEZELS
486-001	LOW AIR PRESSURE INDICATOR LIGHT AND AUDIBLE ALARM
840-002	2 INCH PRIMARY AND SECONDARY AIR PRESSURE GAUGES
198-006	ENGINE COMPARTMENT MOUNTED AIR RESTRICTION INDICATOR WITH GRADUATIONS, WITH WARNING LIGHT IN DASH
149-013	ELECTRONIC CRUISE CONTROL WITH SWITCHES IN LH SWITCH PANEL
156-007	KEY OPERATED IGNITION SWITCH AND INTEGRAL START POSITION; 4 POSITION OFF/RUN/START/ACCESSORY
811-042	ICU3S, 132X48 DISPLAY WITH DIAGNOSTICS, 28 LED WARNING LAMPS AND DATA LINKED
160-038	HEAVY DUTY ONBOARD DIAGNOSTICS INTERFACE CONNECTOR LOCATED BELOW LH DASH
844-001	2 INCH ELECTRIC FUEL GAUGE
845-011	FUEL FILTER RESTRICTION INDICATOR
148-073	ENGINE REMOTE INTERFACE FOR REMOTE THROTTLE

Prepared for:
 Scott Staniszewski
 Super Products Alamo Group
 17000 W Cleveland
 New Berlin, WI 53151
 Phone: 2627847100

Prepared by:
 Tony Bodway
 TRUCK COUNTRY OF
 WISCONSIN, INC.
 2222 WEST RYAN ROAD
 OAK CREEK, WI 53154
 Phone: 414-761-3384

Data Code	Description	Weight Front	Weight Rear
163-004	ENGINE REMOTE INTERFACE CONNECTOR IN ENGINE COMPARTMENT		
856-001	ELECTRICAL ENGINE COOLANT TEMPERATURE GAUGE		
864-001	2 INCH TRANSMISSION OIL TEMPERATURE GAUGE		
830-017	ENGINE AND TRIP HOUR METERS INTEGRAL WITHIN DRIVER DISPLAY		
372-051	CUSTOMER FURNISHED AND INSTALLED PTO CONTROLS		
852-002	ELECTRIC ENGINE OIL PRESSURE GAUGE		
746-115	AM/FM/WB WORLD TUNER RADIO WITH BLUETOOTH AND USB AND AUXILIARY INPUTS, J1939	10	
747-001	DASH MOUNTED RADIO		
750-002	(2) RADIO SPEAKERS IN CAB		
753-001	AM/FM ANTENNA MOUNTED ON FORWARD LH ROOF		
810-027	ELECTRONIC MPH SPEEDOMETER WITH SECONDARY KPH SCALE, WITHOUT ODOMETER		
817-001	STANDARD VEHICLE SPEED SENSOR		
812-001	ELECTRONIC 3000 RPM TACHOMETER		
813-1B4	VT-HU CONNECTIVITY PLATFORM HARDWARE		
8D1-002	2 YEARS DETROIT CONNECT BASE PACKAGE (VIRTUAL TECHNICIAN, DETROIT CONNECT PORTAL ACCESS) FOR VT-HU CONNECTIVITY PLATFORM		
162-002	IGNITION SWITCH CONTROLLED ENGINE STOP		
81Y-001	PRE-TRIP LAMP INSPECTION, ALL OUTPUTS FLASH, WITH SMART SWITCH		
836-015	DIGITAL VOLTAGE DISPLAY INTEGRAL WITH DRIVER DISPLAY		
660-008	SINGLE ELECTRIC WINDSHIELD WIPER MOTOR WITH DELAY		
304-001	MARKER LIGHT SWITCH INTEGRAL WITH HEADLIGHT SWITCH		
882-009	ONE VALVE PARKING BRAKE SYSTEM WITH WARNING INDICATOR		
299-013	SELF CANCELING TURN SIGNAL SWITCH WITH DIMMER, WASHER/WIPER AND HAZARD IN HANDLE		
298-039	INTEGRAL ELECTRONIC TURN SIGNAL FLASHER WITH HAZARD LAMPS OVERRIDING STOP LAMPS		

Prepared for:
 Scott Staniszewski
 Super Products Alamo Group
 17000 W Cleveland
 New Berlin, WI 53151
 Phone: 2627847100

Prepared by:
 Tony Bodway
 TRUCK COUNTRY OF
 WISCONSIN, INC.
 2222 WEST RYAN ROAD
 OAK CREEK, WI 53154
 Phone: 414-761-3384

Data Code	Description	Weight Front	Weight Rear
Design			
065-000	PAINT: ONE SOLID COLOR		
Color			
980-5F6	CAB COLOR A: L0006EB WHITE ELITE BC		
986-020	BLACK, HIGH SOLIDS POLYURETHANE CHASSIS PAINT		
966-972	POWDER WHITE (N0006EA) REAR WHEELS/RIMS (PKWHT21, TKWHT21, W, TW)		
963-003	STANDARD E COAT/UNDERCOATING		
Certification / Compliance			
996-001	U.S. FMVSS CERTIFICATION, EXCEPT SALES CABS AND GLIDER KITS		

Sales Programs

NO SALES PROGRAMS HAVE BEEN SELECTED

TOTAL VEHICLE SUMMARY

Weight Summary

	Weight Front	Weight Rear	Total Weight
Factory Weight ⁺	10117 lbs	8183 lbs	18300 lbs
Total Weight ⁺	10117 lbs	8183 lbs	18300 lbs

Extended Warranty

WAG-010 TOWING: 1 YEAR/UNLIMITED MILES/KM EXTENDED TOWING COVERAGE \$550 CAP FEX APPLIES

(+) Weights shown are estimates only.

Prepared for:
Scott Staniszewski
Super Products Alamo Group
17000 W Cleveland
New Berlin, WI 53151
Phone: 2627847100

Prepared by:
Tony Bodway
TRUCK COUNTRY OF
WISCONSIN, INC.
2222 WEST RYAN ROAD
OAK CREEK, WI 53154
Phone: 414-761-3384

If weight is critical, contact Customer Application Engineering.

Prepared for:
 Scott Staniszewski
 Super Products Alamo Group
 17000 W Cleveland
 New Berlin, WI 53151
 Phone: 2627847100

Prepared by:
 Tony Bodway
 TRUCK COUNTRY OF
 WISCONSIN, INC.
 2222 WEST RYAN ROAD
 OAK CREEK, WI 53154
 Phone: 414-761-3384

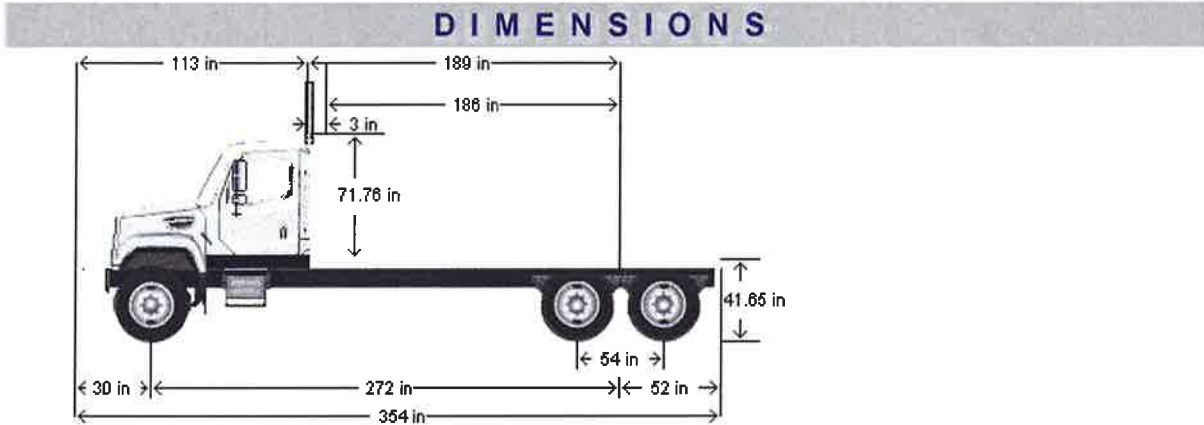

VEHICLE SPECIFICATIONS SUMMARY - DIMENSIONS

Model	114SD
Wheelbase (545)	6900MM (272 INCH) WHEELBASE
Rear Frame Overhang (552)	1325MM (52 INCH) REAR FRAME OVERHANG
Fifth Wheel (578)	NO FIFTH WHEEL
Mounting Location (577)	NO FIFTH WHEEL LOCATION
Maximum Forward Position (in)	0
Maximum Rearward Position (in)	0
Amount of Slide Travel (in)	0
Slide Increment (in)	0
Desired Slide Position (in)	0.0
Cab Size (829)	114 INCH BBC FLAT ROOF ALUMINUM CONVENTIONAL CAB
Sleeper (682)	NO SLEEPER BOX/SLEEPER CAB
Exhaust System (016)	RH OUTBOARD UNDER STEP MOUNTED HORIZONTAL AFTERTREATMENT SYSTEM ASSEMBLY WITH RH B-PILLAR MOUNTED VERTICAL TAILPIPE

TABLE SUMMARY - DIMENSIONS

Prepared for:
 Scott Staniszewski
 Super Products Alamo Group
 17000 W Cleveland
 New Berlin, WI 53151
 Phone: 2627847100

Prepared by:
 Tony Bodway
 TRUCK COUNTRY OF
 WISCONSIN, INC.
 2222 WEST RYAN ROAD
 OAK CREEK, WI 53154
 Phone: 414-761-3384

Dimensions	Inches
Bumper to Back of Cab (BBC)	113.4
Bumper to Centerline of Front Axle (BA)	30.0
Min. Cab to Body Clearance (CB)	3.0
Back of Cab to Centerline of Rear Axle(s) (CA)	188.5
Effective Back of Cab to Centerline of Rear Axle(s) (Effective CA)	185.5
Back of Cab Protrusions (Exhaust/Intake) (CP)	0.0
Back of Cab Protrusions (Side Extenders/Trim Tab) (CP)	0.0
Back of Cab Protrusions (CNG Tank)	0.0
Back of Cab Clearance (CL)	3.0
Back of Cab to End of Frame	240.5
Cab Height (CH)	71.8
Wheelbase (WB)	272.0
Frame Overhang (OH)	52.0
Overall Length (OAL)	354.0
Rear Axle Spacing	54.0
Unladen Frame Height at Centerline of Rear Axle	41.6

Performance calculations are estimates only. If performance calculations are critical, please contact Customer Application Engineering.

Prepared for:
 Scott Staniszewski
 Super Products Alamo Group
 17000 W Cleveland
 New Berlin, WI 53151
 Phone: 2627847100

Prepared by:
 Tony Bodway
 TRUCK COUNTRY OF
 WISCONSIN, INC.
 2222 WEST RYAN ROAD
 OAK CREEK, WI 53154
 Phone: 414-761-3384

FRAME RBM

VEHICLE SPECIFICATIONS SUMMARY - FRAME RBM

Wheelbase (545) 6900MM (272 INCH) WHEELBASE
 Frame Rails (546) 7/16X3-9/16X11-1/8 INCH STEEL FRAME (11.11MMX282.6MM/0.437X11.13 INCH) 120KSI(546)
 Yield Strength (psi) 120000
 Section Modulus (per rail) (cu in) 21.6
 RBM (per rail) (lbf-in) 2592000
 Inner Frame Reinforcement (547) 1/4 INCH (6.35MM) C-CHANNEL INNER FRAME REINFORCEMENT
 Outer Frame Reinforcement (548) NO OUTER FRAME REINFORCEMENT

TABLE SUMMARY - FRAME RBM

Item	Description / Value
Wheelbase	6900MM (272 INCH) WHEELBASE
Frame	7/16X3-9/16X11-1/8 INCH STEEL FRAME (11.11MMX282.6MM/0.437X11.13 INCH) 120KSI
Inner Frame Reinforcement	1/4 INCH (6.35MM) C-CHANNEL INNER FRAME REINFORCEMENT
Outer Frame Reinforcement	NO OUTER FRAME REINFORCEMENT
Yield Strength (psi)	120000
Section Modulus - per rail (cu. in.)	31.00
Frame RBM - per rail (lbf-in)	3715200

Performance calculations are estimates only. If performance calculations are critical, please contact Customer Application Engineering.